

**WINREVAIR®**

(sotatercept)

Powder and Solvent for Solution for Injection (kit)

**1. NAME OF THE MEDICINAL PRODUCT**

WINREVAIR® 45mg Powder and Solvent for Solution for Injection

WINREVAIR® 60mg Powder and Solvent for Solution for Injection

**2. QUALITATIVE AND QUANTITATIVE COMPOSITION**

Winrevair 45 mg powder and solvent for solution for injection

Each vial contains 45 mg of sotatercept. After reconstitution, each mL of solution contains 50 mg sotatercept.

Winrevair 60 mg powder and solvent for solution for injection

Each vial contains 60 mg of sotatercept. After reconstitution, each mL of solution contains 50 mg sotatercept.

Sotatercept is a recombinant homodimeric fusion protein consisting of the extracellular domain of human activin receptor type IIA (ActRIIA) linked to the Fc domain of human IgG1, produced in Chinese Hamster Ovary (CHO) cells by recombinant DNA technology.

For the full list of excipients, see section 6.1.

### 3. PHARMACEUTICAL FORM

Powder and solvent for solution for injection (powder for injection).

Powder: white to off-white powder.

Solvent: clear colourless water for injection.

### 4. CLINICAL PARTICULARS

#### 4.1 Therapeutic indications

Winrevair, in combination with other pulmonary arterial hypertension (PAH) therapies, is indicated for the treatment of PAH in adult patients with WHO Functional Class (FC) II to III, to improve exercise capacity (see section 5.1).

#### 4.2 Posology and method of administration

Winrevair treatment should only be initiated and monitored by a physician experienced in the diagnosis and treatment of PAH.

##### Posology

Winrevair is administered once every 3 weeks as a single subcutaneous injection according to patient weight.

##### *Recommended starting dose*

Haemoglobin (Hgb) and platelet count should be obtained prior to the first dose (see section 4.4). Initiation of treatment is contraindicated if platelet count is consistently  $< 50 \times 10^9/L$  (see section 4.3).

Treatment is initiated with a single dose of 0.3 mg/kg (see Table 1).

**Table 1: Injection volume for dose of 0.3 mg/kg**

Patient weight range (kg)	Injection volume (mL)*	Kit type
30.0 – 40.8	0.2	Kit containing 1 x 45 mg vial
40.9 – 57.4	0.3	
57.5 – 74.1	0.4	
74.2 – 90.8	0.5	
90.9 – 107.4	0.6	
107.5 – 124.1	0.7	
124.2 – 140.8	0.8	
140.9 – 157.4	0.9	
157.5 – 174.1	1.0	Kit containing 1 x 60 mg vial
174.2 – 180.0	1.1	

\*The concentration of the reconstituted solution is 50 mg/mL (see section 6.6)

*Recommended target dose*

Three weeks after a single starting dose of 0.3 mg/kg, the dose should be escalated to the recommended target dose of 0.7 mg/kg after verifying acceptable Hgb and platelet count (see section 4.2 *“Dose adjustments due to increase in haemoglobin or decreased platelet count”*). Treatment should be continued at 0.7 mg/kg every 3 weeks unless dose adjustments are required.

**Table 2: Injection volume for dose of 0.7 mg/kg**

Patient weight range (kg)	Injection volume (mL)*	Kit type
30.0 – 31.7	0.4	Kit containing 1 x 45 mg vial
31.8 – 38.9	0.5	
39.0 – 46.0	0.6	
46.1 – 53.2	0.7	
53.3 – 60.3	0.8	
60.4 – 67.4	0.9	
67.5 – 74.6	1.0	Kit containing 1 x 60 mg vial
74.7 – 81.7	1.1	
81.8 – 88.9	1.2	
89.0 – 96.0	1.3	Kit containing 2 x 45 mg vials
96.1 – 103.2	1.4	
103.3 – 110.3	1.5	
110.4 – 117.4	1.6	
117.5 – 124.6	1.7	
124.7 – 131.7	1.8	
131.8 – 138.9	1.9	Kit containing 2 x 60 mg vials
139.0 – 146.0	2.0	
146.1 – 153.2	2.1	
153.3 – 160.3	2.2	
160.4 – 167.4	2.3	
167.5 and above	2.4	

\*The concentration of the reconstituted solution is 50 mg/mL (see section 6.6)

*Dose adjustments due to increase in haemoglobin or decreased platelet count*

Hgb and platelet count should be monitored for the first 5 doses, or longer if values are unstable. Thereafter, Hgb and platelet count should be verified every 3 to 6 months and the dose adjusted if necessary (see sections 4.4 and 4.8).

Treatment should be delayed for 3 weeks (i.e., one dose delay) if any of the following occur:

- Hgb increases > 1.24 mmol/L (2 g/dL) from the previous dose and is above the ULN.
- Hgb increases > 2.48 mmol/L (4 g/dL) from baseline.
- Hgb increases > 1.24 mmol/L (2 g/dL) above ULN.
- Platelet count decreases <  $50 \times 10^9/L$ .

Hgb and platelet count should be obtained again before reinitiating treatment.

For treatment delays lasting > 9 weeks, treatment should be restarted at 0.3 mg/kg, and the dose should be escalated to 0.7 mg/kg after verifying acceptable Hgb and platelet count.

For treatment delays lasting > 9 weeks due to platelet counts consistently <  $50 \times 10^9/L$ , the physician should carry out a benefit/risk re-evaluation for the patient before reinitiating treatment.

#### *Missed dose*

If a dose is missed, administer as soon as possible. If the missed dose is not taken within 3 days of the scheduled date, adjust the schedule to maintain 3-week dosing intervals.

#### *Elderly*

No dose adjustment is required in elderly patients  $\geq 65$  years old (see section 5.2).

#### *Renal impairment*

No dose adjustment is required based on renal impairment (see section 5.2). Sotatercept has not been studied in PAH patients with severe renal impairment (estimated glomerular filtration rate (eGFR) <30 mL/min/1.73m<sup>2</sup>).

#### *Hepatic impairment*

No dose adjustment is required based on hepatic impairment (Child-Pugh Classification A to C). Sotatercept has not been studied in patients with hepatic impairment (see section 5.2).

#### *Paediatric population*

The safety and efficacy of Winrevair in children and adolescents below 18 years of age have not yet been established. No data are available.

## Method of administration

Winrevair is for single use only.

It should be reconstituted before use. The reconstituted medicinal product is a clear to opalescent and colourless to slightly brownish-yellow solution.

Winrevair should be administered by subcutaneous injection in the abdomen (at least 5 cm away from navel), upper arm, or upper thigh. It should not be injected into sites that are scarred, tender, or bruised. The same injection site should not be used on two consecutive injections.

Winrevair powder and solvent for solution for injection is intended for use under the guidance of a healthcare professional (HCP). Patients and caregivers may administer the medicinal product when considered appropriate and when they receive training from a HCP in how to reconstitute, prepare, measure and inject Winrevair powder and solvent for solution for injection. A HCP should confirm at a subsequent visit, soon after training, that the patient or caregiver can perform these steps correctly. A HCP should also consider reconfirming the patient's or caregiver's administration technique if the dose is adjusted, if the patient requires a different kit, if the patient develops erythrocytosis (see section 4.4), or at any time at the discretion of the HCP.

Refer to section 6.6 for detailed instructions on the proper preparation and administration of Winrevair.

### **4.3 Contraindications**

Hypersensitivity to the active substance or to any of the excipients listed in section 6.1.

Patients with platelet counts consistently  $< 50 \times 10^9/L$  before initiating treatment.

## 4.4 Special warnings and precautions for use

### Traceability

In order to improve the traceability of biological medicinal products, the name and the batch number of the administered product should be clearly recorded.

### Erythrocytosis

Increases in Hgb have been observed in patients during treatment with sotatercept. Severe erythrocytosis may increase the risk of thromboembolic events and hyperviscosity syndrome. Use caution in patients with erythrocytosis who are at increased risk of thromboembolic events. Hgb should be monitored before each dose for the first 5 doses, or longer if values are unstable, and every 3 to 6 months thereafter to determine if dose adjustments are required (see sections 4.2 and 4.8). If a patient develops erythrocytosis, HCP should consider re-evaluating the patient's or caregiver's administration technique.

### Severe thrombocytopenia

Decreased platelet count has been observed in some patients taking sotatercept including severe thrombocytopenia (platelet count  $< 50 \times 10^9/L$ ). Thrombocytopenia was reported more frequently in patients also receiving prostacyclin infusion (21.5%) compared to patients not receiving prostacyclin infusion (3.1%) (see section 4.8). Severe thrombocytopenia may increase the risk of bleeding events. Platelet count should be monitored before each dose for the first 5 doses, or longer if values are unstable, and every 3 to 6 months thereafter to determine whether dose adjustments are required (see section 4.2).

### Serious bleeding

In clinical studies, serious bleeding events (including gastrointestinal, intracranial haemorrhage) have been observed in 4.3% of patients during treatment with sotatercept (see section 4.8).

Patients with serious bleeding events were more likely to be on prostacyclin background therapy and/or antithrombotic agents, have low platelet count, or be 65 years of age or older. Patients should be advised about any signs and symptoms of blood loss. A physician should evaluate and treat bleeding events accordingly. Sotatercept should not be administered if the patient is experiencing a serious bleeding event.

#### Limitation of the clinical data

The clinical studies did not include participants with human immunodeficiency virus (HIV)-, portal hypertension-, schistosomiasis-, or pulmonary veno occlusive disease (PVOD)-associated PAH.

#### Excipients with known effect

This medicinal product contains less than 1 mmol sodium (23 mg) per dose, that is to say essentially 'sodium free'.

This medicinal product contains 0.20 mg of polysorbate 80 in each mL of reconstituted solution. Polysorbates may cause allergic reactions.

### **4.5 Interaction with other medicinal products and other forms of interaction**

No interaction studies have been performed.

### **4.6 Fertility, pregnancy and lactation**

#### Women of childbearing potential

Pregnancy testing is recommended for women of childbearing potential before starting treatment. Women of childbearing potential should use effective contraception during treatment and for at least 4 months after the last dose if treatment is discontinued (see section 5.3).

## Pregnancy

There are no data from the use of sotatercept in pregnant women. Studies in animals have shown reproductive toxicity (increases in post-implantation losses, reduction in foetal body weights, and delays in ossification) (see section 5.3).

Winrevair is not recommended during pregnancy and in women of childbearing potential not using contraception.

## Breast-feeding

It is unknown whether sotatercept/metabolites are excreted in human milk. A risk to newborns/infants cannot be excluded.

Breast-feeding should be discontinued during treatment and for 4 months after the last dose of treatment.

## Fertility

Based on findings in animals, sotatercept may impair female and male fertility (see section 5.3).

### **4.7 Effects on ability to drive and use machines**

Sotatercept has no or negligible influence on the ability to drive and use machines.

### **4.8 Undesirable effects**

#### Summary of safety profile

The most frequently reported adverse reactions were headache (24.5%), epistaxis (22.1%), telangiectasia (16.6%), diarrhoea (15.3%), dizziness (14.7%), rash (12.3%), and thrombocytopenia (10.4%).

The most frequently reported serious adverse reactions were thrombocytopenia (< 1%) and epistaxis (< 1%).

The most common adverse reactions leading to discontinuation were epistaxis and telangiectasia.

#### Tabulated list of adverse reactions

The safety of sotatercept was evaluated in the pivotal study STELLAR, a placebo-controlled study of 163 patients with PAH treated with sotatercept (see section 5.1). The median duration of treatment with sotatercept was 313 days.

The adverse reactions reported with sotatercept are listed in the table below by MedDRA system organ class and by frequency. Frequencies are defined as very common ( $\geq 1/10$ ), common ( $\geq 1/100$  to  $< 1/10$ ), uncommon ( $\geq 1/1\ 000$  to  $< 1/100$ ), rare ( $\geq 1/10\ 000$  to  $< 1/1\ 000$ ), and very rare ( $< 1/10\ 000$ ).

**Table 3: Adverse reactions**

System organ class	Frequency	Adverse reaction
Blood and lymphatic system disorders	Very common	Thrombocytopenia <sup>1,2</sup> Increased haemoglobin <sup>1</sup>
Nervous system disorders	Very common	Dizziness Headache
Respiratory, thoracic and mediastinal disorders	Very common	Epistaxis
Gastrointestinal disorders	Very common	Diarrhoea
	Common	Gingival bleeding
Skin and subcutaneous tissue disorders	Very common	Telangiectasia <sup>1</sup> Rash
	Common	Erythema
General disorders and administration site conditions	Common	Injection site pruritus
Investigations	Common	Increased blood pressure <sup>1,3</sup>

<sup>1</sup> See description of selected adverse reactions

<sup>2</sup> Includes 'thrombocytopenia' and 'platelet count decreased'

<sup>3</sup> Includes 'hypertension', 'blood pressure diastolic increased' and 'blood pressure increased'

### Description of selected adverse reactions

#### *Increased haemoglobin*

In STELLAR, adverse reactions of increased Hgb ('haemoglobin increased' and 'polycythaemia') were reported in 8.6% of patients taking sotatercept. Based on laboratory data, moderate elevations in Hgb (> 1.24 mmol/L (2 g/dL) above ULN) occurred in 15.3% of patients taking sotatercept. Increases in Hgb were managed by dose adjustments (see sections 4.2 and 4.4).

#### *Thrombocytopenia*

Thrombocytopenia ('thrombocytopenia' and 'platelet count decreased') was reported in 10.4% of patients taking sotatercept. Severe reduction in platelet count < 50 x 10<sup>9</sup>/L occurred in 2.5% of patients taking sotatercept. Thrombocytopenia was reported more frequently in patients also

receiving prostacyclin infusion (21.5%) compared to patients not receiving prostacyclin infusion (3.1%). Thrombocytopenia was managed by dose adjustments (see sections 4.2 and 4.4).

### *Telangiectasia*

Telangiectasia was observed in 16.6% of patients taking sotatercept. The median time to onset was 18.6 weeks. Discontinuations of treatment due to telangiectasia were 1% in the sotatercept group.

### *Increased blood pressure*

Increased blood pressure was reported in 4.3% of patients taking sotatercept. In patients taking sotatercept, mean systolic blood pressure increased from baseline by 2.2 mmHg and diastolic blood pressure increased by 4.9 mmHg at 24 weeks.

### Elderly

With the exception of bleeding events (a collective group of adverse events of clinical interest), there were no differences in safety between the < 65-year-old and ≥ 65-year-old subgroups. Bleeding events occurred more commonly in the older sotatercept subgroup (52% vs 31.9% in patients < 65-year-old); however, there was no notable imbalance between age categories for any specific bleeding event. Serious bleeding occurred in 3.6% of patients < 65-year-old and in 8.0% of patients ≥ 65-year-old taking sotatercept.

### Long-term safety data

Long-term safety data are available from pooled phase 2 and phase 3 clinical studies (n=431). The median duration of exposure was 657 days. The safety profile was generally similar to that observed in the pivotal STELLAR study.

### Reporting of suspected adverse reactions

Reporting suspected adverse reactions after authorisation of the medicinal product is important. It allows continued monitoring of the benefit/risk balance of the medicinal product.

## 4.9 Overdose

In a phase 1 healthy volunteer study, one participant dosed at 1 mg/kg of sotatercept experienced increased Hgb associated with symptomatic hypertension that improved with phlebotomy.

In the event of overdose in a patient with PAH, increases in Hgb and blood pressure should be closely monitored, and supportive care should be provided as appropriate (see sections 4.2 and 4.4). Sotatercept is not dialyzable during haemodialysis.

## 5. PHARMACOLOGICAL PROPERTIES

### 5.1 Pharmacodynamic properties

Pharmacotherapeutic group: antihypertensives, antihypertensives for pulmonary arterial hypertension. ATC code: C02KX06

#### Mechanism of action

Sotatercept is an activin signalling inhibitor with high selectivity for Activin-A, a dimeric glycoprotein which belongs to the transforming growth factor- $\beta$  (TGF- $\beta$ ) superfamily of ligands. Activin-A binds to the activin receptor type IIA (ActRIIA) regulating key signalling for inflammation, cell proliferation, apoptosis, and tissue homeostasis.

Activin-A levels are increased in PAH patients. Activin binding to ActRIIA promotes proliferative signalling while there is a decrease in anti-proliferative bone morphogenetic protein receptor type II (BMPRII) signalling. The imbalance of ActRIIA-BMPRII signalling underlying PAH results in vascular cell hyperproliferation, causing pathological remodelling of the pulmonary arterial wall, narrowing the arterial lumen, increasing pulmonary vascular resistance, and leads to increased pulmonary artery pressure and right ventricular dysfunction.

Sotatercept consists of a recombinant homodimeric activin receptor type IIA-Fc (ActRIIA-Fc) fusion protein, which acts as a ligand trap that scavenges excess Activin-A and other ligands for ActRIIA to inhibit activin signalling. As a result, sotatercept rebalances the pro-proliferative (ActRIIA/Smad2/3-mediated) and anti-proliferative (BMPRII/Smad1/5/8-mediated) signalling to modulate vascular proliferation.

### Pharmacodynamic effects

A phase 2 clinical study (PULSAR) assessed pulmonary vascular resistance (PVR) in patients with PAH after 24 weeks of treatment with sotatercept. The decrease from baseline in PVR was significantly greater in the sotatercept 0.7 mg/kg and 0.3 mg/kg groups compared with the placebo group. The placebo-adjusted least squares (LS) mean difference from baseline was  $-269.4 \text{ dyn}\cdot\text{sec}/\text{cm}^5$  (95% CI:  $-365.8, -173.0$ ) for the sotatercept 0.7 mg/kg group and  $-151.1 \text{ dyn}\cdot\text{sec}/\text{cm}^5$  (95% CI:  $-249.6, -52.6$ ) for the sotatercept 0.3 mg/kg group.

In rat models of PAH, a sotatercept analogue reduced expression of pro-inflammatory markers at the pulmonary arterial wall, reduced leucocyte recruitment, inhibited proliferation of endothelial and smooth muscle cells, and promoted apoptosis in diseased vasculature. These cellular changes were associated with thinner vessel walls, reversed arterial and right ventricular remodelling, and improved haemodynamics.

### Clinical efficacy and safety

The efficacy of sotatercept was evaluated in adult patients with PAH in the pivotal STELLAR study. STELLAR was a double-blind, placebo-controlled, multicentre, parallel-group clinical study in which 323 patients with PAH (WHO Group 1 Functional Class II or III) were randomised 1:1 to sotatercept (starting dose 0.3 mg/kg escalated to target dose 0.7 mg/kg) (n=163) or placebo (n=160) administered subcutaneously once every 3 weeks. Patients continued their treatment assignment in the long-term double-blind treatment period until all patients completed Week 24.

Participants in this study were adults with a median age of 48.0 years (range: 18 to 82 years), of which 16.7% were  $\geq 65$  years of age. Median weight was 68.2 kg (range: 38.0 to 141.3 kg);

89.2% of participants were White, and 79.3% were not Hispanic or Latino; and 79.3% were female. The most common PAH aetiologies were idiopathic PAH (58.5%), heritable PAH (18.3%), and PAH associated with connective tissue diseases (14.9%), PAH associated with simple congenital heart disease with repaired systemic-to-pulmonary shunts (5%), or drug or toxin-induced PAH (3.4%). The mean time since PAH diagnosis to screening was 8.76 years.

Most participants were receiving either triple (61.3%) or double (34.7%) background PAH therapy, and more than one-third (39.9%) were receiving prostacyclin infusions. The proportions of participants in WHO FC II was 48.6% and in WHO FC III was 51.4%. The STELLAR study excluded patients diagnosed with HIV-associated PAH, PAH associated with portal hypertension, schistosomiasis-associated PAH, and PVOD.

The primary efficacy endpoint was the change from baseline at Week 24 in 6-Minute Walk Distance (6MWD). In the sotatercept treatment group, the median of the placebo-adjusted change in 6MWD from baseline at Week 24 was 40.8 meters (95% CI: 27.5, 54.1;  $p < 0.001$ ). The median of the placebo-adjusted changes in 6MWD at Week 24 were also evaluated in subgroups. The treatment effect was consistent across the different subgroups including sex, PAH diagnostic group, background therapy at baseline, prostacyclin infusion therapy at baseline, WHO FC, and baseline PVR.

The secondary endpoints included improvements in multicomponent improvement (MCI), PVR, N-terminal pro-B-type natriuretic peptide (NT-proBNP), WHO FC, time to death or first occurrence of clinical worsening events.

MCI was a pre-defined endpoint measured by the proportion of patients achieving all three of the following criteria at Week 24 relative to baseline: improvement in 6MWD (increase  $\geq 30$  m), improvement in NT-proBNP (decrease in NT-proBNP  $\geq 30\%$  or maintenance/achievement of NT-proBNP level  $< 300$  ng/L), and improvement in WHO FC or maintenance of WHO FC II.

Disease progression was measured by the time to death or first occurrence of a clinical worsening event. Clinical worsening events included worsening-related listing for lung and/or heart transplant, need to initiate rescue therapy with an approved background PAH therapy or the need to increase the dose of infusion prostacyclin by  $\geq 10\%$ , need for atrial septostomy,

hospitalisation for worsening PAH ( $\geq 24$  hours), or deterioration of PAH (worsened WHO FC and decrease in 6MWD  $\geq 15\%$  with both events occurring at the same time or different times). Clinical worsening events and death were captured until the last patient completed the Week 24 visit (data up to the data cutoff; median duration of exposure 33.6 weeks).

At Week 24, 38.9% of sotatercept-treated patients showed improvement in MCI versus 10.1% in the placebo group ( $p < 0.001$ ). The median treatment difference in PVR between sotatercept and placebo group was  $-234.6 \text{ dyn}\cdot\text{sec}/\text{cm}^5$  (95% CI:  $-288.4, -180.8$ ;  $p < 0.001$ ). The median treatment difference in NT-proBNP between the sotatercept and placebo groups was  $-441.6 \text{ pg}/\text{mL}$  (95% CI:  $-573.5, -309.6$ ;  $p < 0.001$ ). Improvement in WHO FC from baseline occurred in 29% of patients in sotatercept versus 13.8% in placebo ( $p < 0.001$ ).

Treatment with sotatercept resulted in an 82% reduction (HR 0.182, 95% CI: 0.075, 0.441;  $p < 0.001$ ) in the occurrence of death or clinical worsening events compared to placebo (see Table 4). The treatment effect of sotatercept versus placebo started by Week 10 and continued for the duration of the study.

**Table 4: Death or clinical worsening events**

	<b>Placebo (N=160)</b>	<b>Sotatercept (N=163)</b>
Total number of subjects who experienced death or at least one clinical worsening event, n (%)	29 (18.1)	7 (4.3)
Assessment of death or first occurrence of clinical worsening events*, n (%)		
Death	6 (3.8)	2 (1.2)
Worsening-related listing for lung and/or heart transplant	1 (0.6)	1 (0.6)
Need for atrial septostomy	0 (0.0)	0 (0.0)
PAH-specific hospitalisation (≥24 hours)	8 (5.0)	0 (0.0)
Deterioration of PAH†	15 (9.4)	4 (2.5)

\* A subject can have more than one assessment recorded for their first event of clinical worsening. There were 2 participants receiving placebo and no participant receiving sotatercept who had more than one assessment recorded for their first event of clinical worsening. This analysis excluded the component “need to initiate rescue therapy with an approved PAH therapy or need to increase the dose of infusion prostacyclin by 10% or more”.

† Deterioration of PAH is defined by both of the following events occurring at any time, even if they began at different times, as compared to their baseline values: (a) Worsened WHO functional class (II to III, III to IV, II to IV, etc.); and (b) Decrease in 6MWD by ≥ 15% (confirmed by two 6MWTs at least 4 hours apart but no more than one week).

N = number of subjects in FAS population; n = number of subjects in the category. Percentages are calculated as (n/N)\*100.

### Immunogenicity

At Week 24 in STELLAR, anti-drug antibodies (ADA) were detected in 44/163 (27%) of patients taking sotatercept. Among these 44 patients, 12 tested positive for neutralising antibodies against sotatercept. No evidence of ADA impact on pharmacokinetics, efficacy or safety was observed.

## 5.2 Pharmacokinetic properties

In patients with PAH, the geometric mean (%Coefficient of variation (CV %)) steady-state AUC and steady-state peak concentration ( $C_{max}$ ) at the dose of 0.7 mg/kg every 3 weeks were 171.3 mcg×d/mL (34.2%) and 9.7 mcg/mL (30%), respectively. Sotatercept AUC and  $C_{max}$  increase proportionally with dose. Steady state is achieved after approximately 15 weeks of treatment. The accumulation ratio of sotatercept AUC was approximately 2.2.

### Absorption

The subcutaneous (SC) formulation has an absolute bioavailability of approximately 66% based on population pharmacokinetics analysis. The maximum sotatercept concentration is achieved at a median time to peak drug concentration ( $T_{max}$ ) of approximately 7 days (range from 2 to 8 days) after multiple dosing every 4 weeks.

### Distribution

The central volume of distribution (CV%) of sotatercept is approximately 3.6 L (24.7%). The peripheral volume of distribution (CV%) is approximately 1.7 L (73.3%).

### Biotransformation

Sotatercept is catabolised by general protein degradation processes.

### Elimination

Sotatercept clearance is approximately 0.18 L/day. The geometric mean terminal half-life (CV%) is approximately 21 days (33.8%).

### Specific populations

*Age, sex, and ethnic origin*

No clinically significant differences in sotatercept pharmacokinetics (PK) were observed based on age (18 to 81 years of age), sex, or ethnic origin (82.9% Caucasian, 3.1% Black, 7.1% Asian, and 6.9% other).

#### *Body weight*

The clearance and central volume of distribution of sotatercept increase with increasing body weight. The recommended weight-based dosing regimen results in consistent sotatercept exposures.

#### *Renal impairment*

Sotatercept pharmacokinetics was comparable in PAH patients with mild to moderate renal impairment (eGFR ranging from 30 to 89 mL/min/1.73m<sup>2</sup>) to those with normal renal function (eGFR ≥90 mL/min/1.73m<sup>2</sup>). Additionally, sotatercept PK is comparable between non-PAH end-stage renal disease (ESRD) patients and patients with normal renal function. Sotatercept is not dialyzable during haemodialysis. Sotatercept has not been studied in PAH patients with severe renal impairment (eGFR <30 mL/min/1.73m<sup>2</sup>).

#### *Hepatic impairment*

Sotatercept has not been studied in PAH patients with hepatic impairment (Child-Pugh Classification A to C). Hepatic impairment is not expected to influence sotatercept metabolism since sotatercept is metabolised via cellular catabolism.

### **5.3 Preclinical safety data**

No carcinogenicity or mutagenicity studies have been conducted with sotatercept.

#### Repeat dose toxicity

In rats and monkeys, the longest SC toxicity studies were 3 months and 9 months in duration, respectively. In rats, adverse findings included efferent duct/testicular degeneration, adrenal gland congestion/necrosis, and membranoproliferative glomerulonephritis and tubulointerstitial nephritis in the kidneys. Kidney changes were not reversible following a 1-month recovery period. In monkeys, adverse changes included increased interstitial matrix at the

corticomedullary junction, decreased glomerular tuft size, glomerulonephritis and tubulointerstitial nephritis in the kidney. Kidney changes in monkeys partially resolved following a 3-month recovery period. At the no observed adverse effect level (NOAEL) in rats and monkeys, sotatercept exposures were  $\leq 2$ -times the clinical exposure at the maximum recommended human dose (MRHD). Other findings that occurred at clinical exposure margins in monkeys included hepatic inflammatory infiltrates, lymphoid depletion in spleen, and inflammatory infiltrates in the choroid plexus.

### Reproductive toxicity

In a female fertility study, oestrous cycle duration was increased, pregnancy rates were decreased, there were increases in pre-implantation and post-implantation loss and reductions in live litter size. At the NOAEL for female fertility endpoints, sotatercept exposure was 2-times the clinical AUC at the MRHD.

In males, there were non-reversible histologic changes in the efferent ducts, testes, and epididymides. Histomorphologic changes in rat testes correlated to decreased fertility index that reversed during the 13-week treatment-free period. A NOAEL for testicular histologic changes was not established and the NOAEL for male fertility functional changes provides a systemic exposure 2-times the clinical exposure at the MRHD.

In embryo-fetal developmental toxicity studies, effects in rats and rabbits included reductions in numbers of live fetuses and fetal body weights, delays in ossification, and increases in resorptions and post-implantation losses. In rats only, there were also skeletal variations (increased number of supernumerary ribs and changes in the number of thoracic or lumbar vertebrae). At the NOAEL in rats and rabbits, sotatercept exposures were 2-times and 0.4-times, respectively, the clinical exposure at the MRHD.

In a pre- and postnatal development study in rats, no sotatercept related adverse effects were observed in first filial generation (F1) pups from dams dosed during gestation at estimated exposures up to 2-times the MRHD. In F1 pups from dams dosed during lactation, decreases in pup weight correlated with delays in sexual maturation. The NOAEL for effects on growth and maturation in pups provides a systemic exposure 0.6-times the clinical exposure at the MRHD.

## **6. PHARMACEUTICAL PARTICULARS**

### **6.1 List of excipients**

#### Powder

Citric acid monohydrate (E330)

Trisodium citrate, dihydrate (E331)

Polysorbate 80 (E433)

Sucrose

#### Solvent

Water for injection

### **6.2 Incompatibilities**

This medicinal product must not be mixed with other medicinal products except those mentioned in section 6.6.

### **6.3 Shelf life**

#### Unopened vial

3 years

### After reconstitution

Biochemical and biophysical in-use stability has been demonstrated for 4 hours at 30 °C.

From a microbiological point of view, the medicinal product should be used immediately or no longer than 4 hours after reconstitution.

If not used immediately, in-use storage times and conditions prior to use are the responsibility of the user.

### **6.4 Special precautions for storage**

Store in a refrigerator (2 °C – 8 °C). Do not freeze.

Store in the original package in order to protect from light.

For storage conditions after reconstitution of the medicinal product, see section 6.3.

### **6.5 Nature and contents of container**

#### Winrevair 45 mg powder and solvent for solution for injection

2 mL capacity, type I glass vial sealed with a bromobutyl rubber stopper with polymer coating and aluminium seal with lime polypropylene flip-off cap containing 45 mg of sotatercept.

Prefilled syringe (type I glass cartridge closed with a bromobutyl rubber stopper) with 1 mL of solvent.

#### Winrevair 60 mg powder and solvent for solution for injection

2 mL capacity, type I glass vial sealed with a bromobutyl rubber stopper with polymer coating and aluminium seal with burgundy polypropylene flip-off cap containing 60 mg of sotatercept.

Prefilled syringe (type I glass cartridge closed with a bromobutyl rubber stopper) with 1.3 mL of solvent.

Winrevair powder and solvent for solution for injection is available as the following pack sizes:

- Kits containing 1 vial with 45 mg powder, 1 prefilled syringe with 1.0 mL solvent, 1 dosing syringe with 0.1 mL graduations, 1 vial adaptor (13 mm), 1 needle for injection and 4 alcohol wipes.
- Kits containing 2 vials with 45 mg powder, 2 prefilled syringes with 1.0 mL solvent, 1 dosing syringe with 0.1 mL graduations, 2 vial adaptors (13 mm), 1 needle for injection and 8 alcohol wipes.
- Kits containing 1 vial with 60 mg powder, 1 prefilled syringe with 1.3 mL solvent, 1 dosing syringe with 0.1 mL graduations, 1 vial adaptor (13 mm), 1 needle for injection and 4 alcohol wipes.
- Kits containing 2 vials with 60 mg powder, 2 prefilled syringes with 1.3 mL solvent, 1 dosing syringe with 0.1 mL graduations, 2 vial adaptors (13 mm), 1 needle for injection and 8 alcohol wipes.

Not all pack sizes may be marketed.

## **6.6 Special precautions for disposal and other handling**

### Selecting the appropriate product kit

If a patient's weight requires the use of two 45 mg or two 60 mg vials, a 2-vial kit should be used instead of two 1-vial kit to eliminate the need for multiple injections (see section 6.5).

### Reconstitution and administration instructions

Winrevair powder and solvent for solution for injection should be reconstituted before use and

administered as a single injection according to patient weight (see section 4.2).

See the separate Instructions for Use booklet provided in the kit for detailed step by step instructions on how to prepare and administer the medicinal product. An overview of the reconstitution and administration instructions is provided below.

### *Reconstitution*

- Remove the kit from the refrigerator and wait 15 minutes to allow the prefilled syringe(s) and medicinal product to come to room temperature prior to preparation.
- Check the vial to ensure the medicinal product is not expired. The powder should be white to off-white and may look like a whole or broken up cake.
- Remove the lid from the vial containing the powder and swab the rubber stopper with an alcohol wipe.
- Attach the vial adaptor to the vial.
- Visually inspect the prefilled syringe for any damage or leaks and the sterile water inside to ensure there are no visible particles.
- Break off the cap of the prefilled syringe and attach the syringe to the vial adaptor.
- Inject all of the sterile water from the attached syringe into the vial containing the powder:
  - The prefilled syringe provided with the vial 45 mg contains 1.0 mL of sterile water.
  - The prefilled syringe provided with the vial 60 mg contains 1.3 mL of sterile water.After reconstitution, the 45 mg vial can only provide up to a dose of 0.9 mL of medicinal product and the 60 mg vial can only provide up to a dose of 1.2 mL of medicinal product. The final concentration after reconstitution is 50 mg/mL.
- Gently swirl the vial to reconstitute the medicinal product. Do not shake or vigorously agitate.
- Allow the vial to stand for up to 3 minutes to allow bubbles to disappear.
- Visually inspect the reconstituted solution. When properly mixed, the reconstituted solution should be clear to opalescent and colourless to slightly brownish-yellow, and should not have clumps or powder.
- Unscrew the syringe from the vial adaptor and discard the emptied syringe.
- If prescribed a 2-vial kit, repeat the steps within this section to prepare the second vial.
- Use the reconstituted solution as soon as possible, but no later than 4 hours after

reconstitution.

### *Dosing syringe preparation*

- Before preparing the dosing syringe, visually inspect the reconstituted solution. The reconstituted solution should be clear to opalescent and colourless to slightly brownish-yellow, and should not have clumps or powder.
- Swab the vial adaptor with an alcohol wipe.
- Remove the dosing syringe from its packaging and attach the syringe to the vial adaptor.
- Turn the syringe and vial upside-down and withdraw the appropriate volume for injection, based on the patient's weight.
  - If the dose amount requires the use of two vials, withdraw the entire contents of the first vial and slowly transfer the entire contents into the second vial, to ensure dose accuracy.
  - Turn the syringe and vial upside-down and withdraw the required amount of medicinal product.
- If necessary, push the plunger in to remove excess medicinal product or air from the syringe.
- Remove the syringe from the vial adaptor and attach the needle.

### *Administration*

Winrevair is to be administered as a single subcutaneous injection.

- Select the injection site on the abdomen (at least 5 cm away from navel), upper thigh, or upper arm and swab with an alcohol wipe. Select a new site for each injection that is not scarred, tender, or bruised.

- For administration by the patient or caregiver, train them to inject only in the abdomen or upper thigh (see “**Instructions for Use**” booklet).
- Perform subcutaneous injection.
- Discard the emptied syringe. Do not reuse the syringe.

Any unused medicinal product or waste material should be disposed of in accordance with local requirements.

See section 4.4 for instructions on the traceability of biological medicinal products.

## **7. MANUFACTURED BY**

**Patheon Italia S.p.A**

Viale G.B. Stucchi, 110-20900 Monza (MB), Italy

## **8. PACKED AND RELEASED BY**

**MERCK SHARP & DOHME B.V.**

Waarderweg 39, Haarlem, 2031 BN, Netherlands

## **9. MARKETING AUTHORIZATION HOLDER**

**MERCK SHARP & DOHME (MALAYSIA) SDN. BHD.**

Lot No. B-22-1 & B-22-2, Level 22

The Ascent, Paradigm No. 1

Jalan SS 7/26A, Kelana Jaya

47301 Petaling Jaya

Selangor, Malaysia

Date of Revision: 21 November 2025

Copyright © 2025 Merck & Co., Inc., Rahway, NJ, USA and its affiliates.

All rights reserved.

**IMPORTANT: read this booklet before use**

Important

# Instructions for Use

**WINREVAIR<sup>®</sup>** sotatercept

45 mg powder and solvent for solution for injection (1 vial - pack)

60 mg powder and solvent for solution for injection (1 vial - pack)

Mix

This booklet contains instructions on how to prepare and inject Winrevaair powder and solvent for solution for injection. The package leaflet, also provided in the pack, contains all the important information for you.

Withdraw

Dose based on patient weight

**For subcutaneous (SC) injection only** (inject directly under the skin)

Inject



## In this booklet (Important):

Before you start.....	4
Important information for healthcare professionals .....	5
Get to know the parts of your pack.....	6
Important information to know before injecting .....	8
Storing your pack .....	9
Get started .....	10
● <b>Mix</b> powdered medicine into liquid form .....	12
● <b>Withdraw</b> your prescribed dose .....	24
● <b>Inject</b> your medicine .....	34
How to throw away WINREVAIR .....	36
Frequently asked questions .....	38

## Before you start:



### **Read this booklet**

Read these instructions from start to finish before you use WINREVAIR for the first time and before every administration. There may be new information.



### **Start with your doctor or nurse**

Do not use WINREVAIR until your doctor or nurse has shown you or your caregiver the right way to prepare and inject it. Your doctor or nurse should show you how to inject WINREVAIR before you use it for the first time.



### **Questions?**

If you have questions about how to give Winrevair the right way or need more information, talk to your doctor, pharmacist, or nurse.



## Important information for healthcare professionals

A healthcare professional will provide training regarding proper preparation and administration of Winrevair following this “Instructions for Use” (IFU) booklet step-by-step, and decide whether a patient or caregiver is capable of preparing and administering Winrevair independently.

Make sure the patient or caregiver can do the following correctly:

1. Reconstitute the medicine
2. Measure the correct amount of medicine according to patient’s prescription
3. Select and prepare a proper injection site
4. Inject the medicine subcutaneously

# Get to know the parts of your pack

## Top Tray

Use to **mix** the medicine

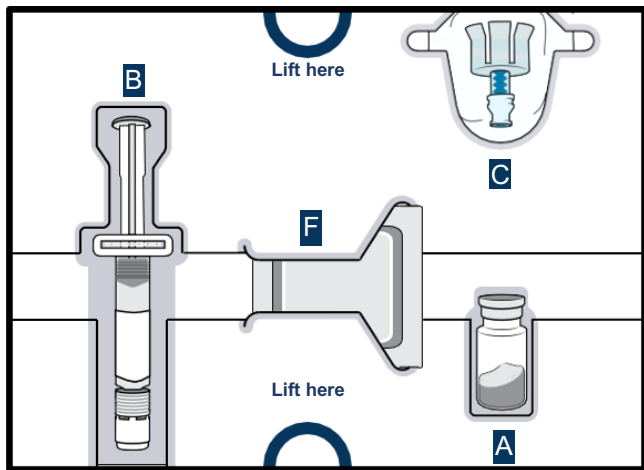

**A - 1 Vial of  
WINREVAIR  
medicine powder**



**B - 1 Prefilled  
syringe (solvent)  
with sterile water to  
mix medicine  
powder into liquid**

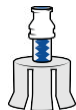

**C - 1 Vial adaptor  
to connect the vial  
and syringe**

## Bottom Tray

Use to **inject** the medicine

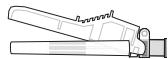
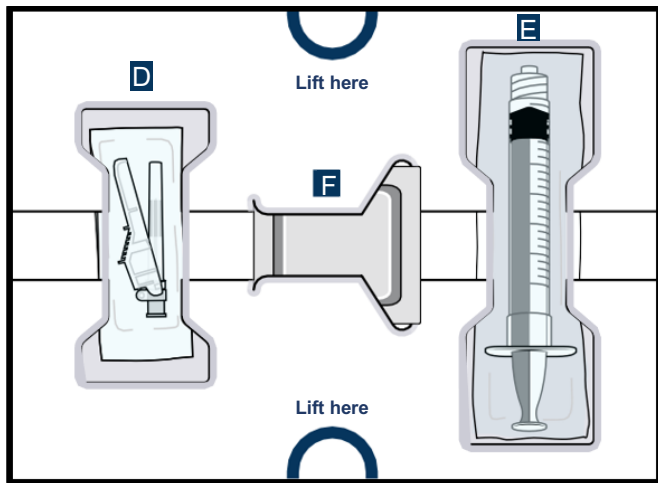

**D - 1 Needle** for injection

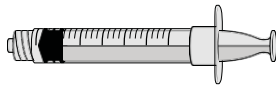

**E - 1 Empty dosing syringe**  
to measure, withdraw, and  
inject your medicine

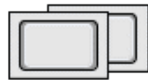

**F - 4 Alcohol wipes**  
(2 on each tray)

# Important information to know before injecting

- You must mix this product before using it. Make sure the medicine powder in the vial is completely dissolved when you inject it.
- **Check your prescribed dose (amount in ‘mL’) each time you use the product. Your prescribed dose may change.**
- Use only the supplies that are in the pack to prepare your prescribed dose.
- Do not open the pack or mix the medicine until you are ready to use it.
- **Do not reuse any of the supplies.** After your injection, dispose of any unused medicine and used supplies according to local requirements. See pages 36-37 for more information.

## Storing your pack

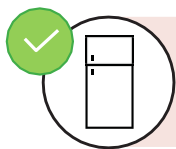

Store the entire pack in the refrigerator, but do not freeze.

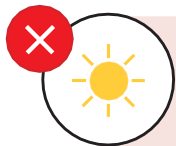

Keep the medicine and supplies in the pack and away from light.



Keep pack out of the sight and reach of children and pets.

# Get Started

Any patient or caregiver who is to prepare and inject WINREVAIR must first be trained and deemed capable of independent administration of WINREVAIR by a healthcare professional.

## 1 Check WINREVAIR product and expiry date

Remove the WINREVAIR pack from the refrigerator.

✓ **Check the expiry date and look for any signs of damage** on the pack or in the supplies.

⚠ If expired or damaged, do not use. Talk to your doctor or pharmacist immediately to get a new pack.

✓ **Check that you have the medicine** that your doctor prescribed.

**2**

## Let your pack come to room temperature, gather supplies, and wash your hands

Wait 15 minutes to allow your pack to warm to room temperature.

Cold medicine is more painful to inject.

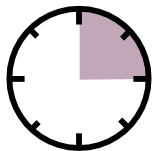

**15 minutes**

Along with your pack, gather these items and find a clean, flat surface where you will prepare and inject your dose.



Sharps disposal container



Gauze, cotton ball, or bandage

Wash your hands with soap and water.

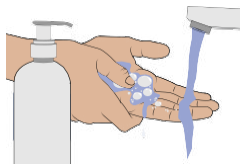

# Mix powdered medicine into liquid form (Mix)

Start with the Top Tray

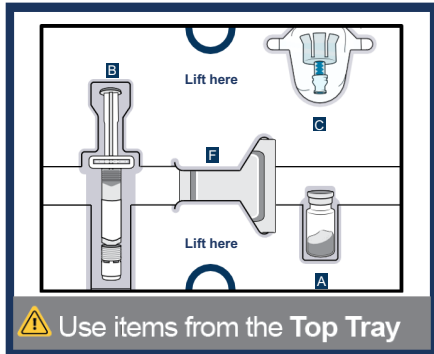

3

Remove vial, prefilled syringe, and vial adaptor from the pack

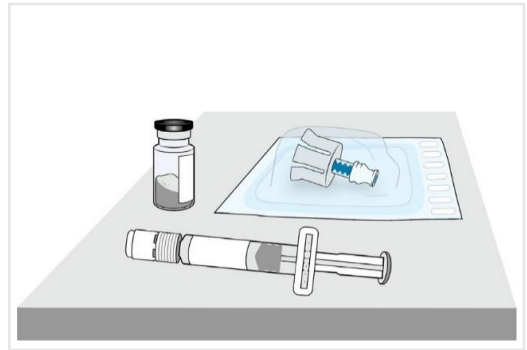

## 4a Check the medicine and the vial

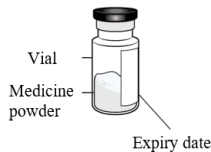

- ✓ Not damaged?
- ✓ No visible particle?
- ✓ Not expired?

Check the vial label to **confirm the medicine is not expired**. Visually inspect the medicine powder. It should be white to off-white and may look like a whole or broken up cake.

⚠ Do not use if expired, damaged, or you can see particles in it.

## 4b Remove plastic cap and clean the vial

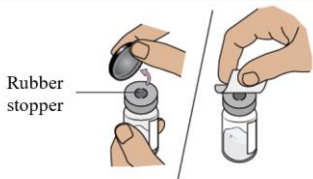

Flip off the plastic cap and **clean the rubber stopper on top of the vial** with an alcohol wipe.

- ⚠ Do not use if vial cap is missing
- ⚠ Do not touch the cleaned rubber stopper

Set vial aside on a clean, flat surface.

## 5a Align vial adaptor to vial

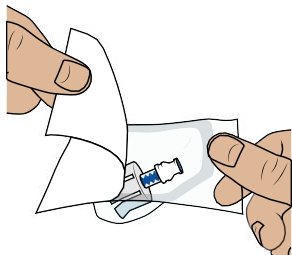

Peel open the vial adaptor package and remove it from its package.



**Hold the blue neck of the adaptor** and align the vial adaptor on top of the vial.

 Do not touch the inside of the vial adaptor to keep it clean and avoid sharps

To attach the vial adaptor:

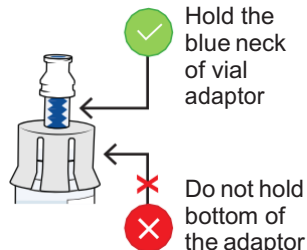

## 5b Attach vial adaptor to vial

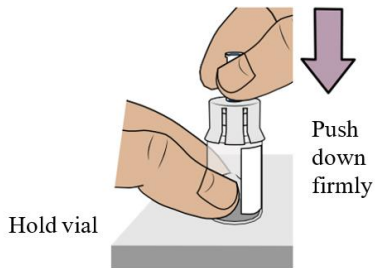

Hold the vial with one hand. **Push the vial adaptor down firmly** so it snaps in place (you may feel some resistance).

## 5c Clean vial adaptor



Clean the top of the vial adaptor with an alcohol wipe.

## 6 Check prefilled syringe

Confirm the product is not expired. Visually inspect that the sterile water inside the prefilled syringe is clear.

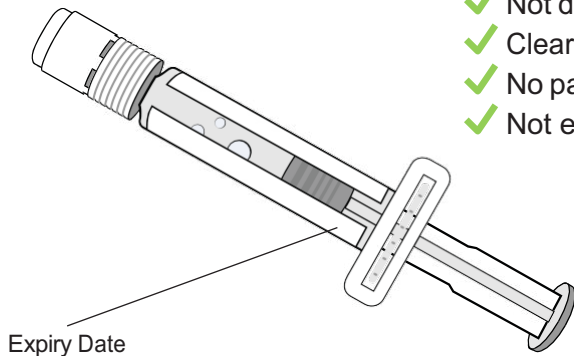

- ✓ Not damaged?
- ✓ Clear?
- ✓ No particles?
- ✓ Not expired?

 Do not use if you see any clumps, particles, discolouration, or product is expired.

## 7 Break off prefilled syringe white cap

Break off the prefilled syringe cap along the perforation.

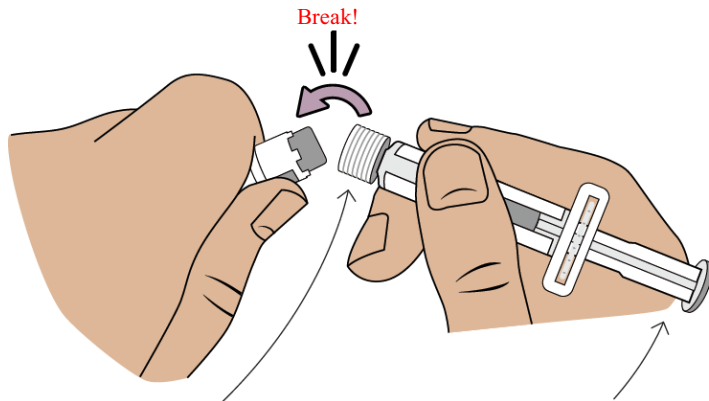

**⚠** Do not touch the tip of the prefilled syringe

**⚠** Do not push the plunger; it may spill the sterile water

## 8 Connect prefilled syringe to vial adaptor

Now, pick up the medicine vial with the vial adaptor attached.

**Align the prefilled syringe tip on the blue circle of the vial adaptor.**

**Push and twist the prefilled syringe onto the vial adaptor until you cannot turn further.** While twisting, be sure to hold onto the vial adaptor.

**Push then twist** until connected

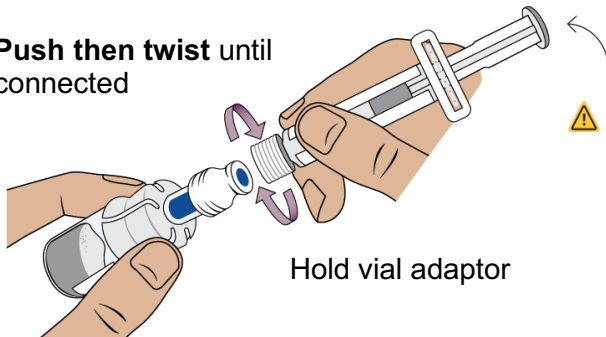

Do not push the plunger; it may spill the sterile water

## 9 Transfer sterile water from prefilled syringe to vial

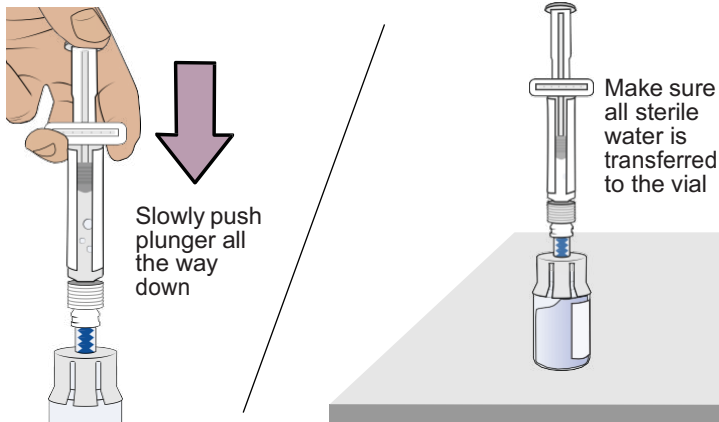

*Slowly* push the plunger all the way down to transfer all the sterile water into the vial (the plunger will move up; this is normal).

## 10 Swirl to mix medicine



 Do not shake the vial

Hold the prefilled syringe and **gently swirl the vial in a circular motion** until the powder is fully dissolved. This may take up to **2 minutes**. **Do not shake or agitate vigorously.**

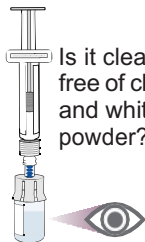

When the medicine is mixed well, it should be clear. If not, repeat this step until it is clear.

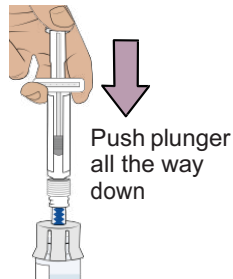

**Press the plunger down** again to make sure all the liquid is in the vial since some liquid could have moved back into the syringe (the plunger will move up; this is normal).

**11**

## Wait for the bubbles to go away

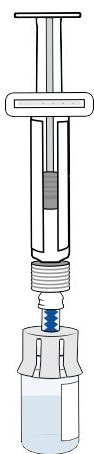

3 minutes

**Set the vial aside for bubbles to go away.**  
This may take up to 3 minutes.



Before you continue, make sure the medicine in the vial:

- ✓ Is clear to opalescent and colourless to slightly brownish-yellow.
- ✓ Does not have clumps or powder.
- ✓ Does not have large bubbles.

It is okay to have slight foam (small bubbles) around the edges of the vial.

## 12 Prepare vial by removing extra air

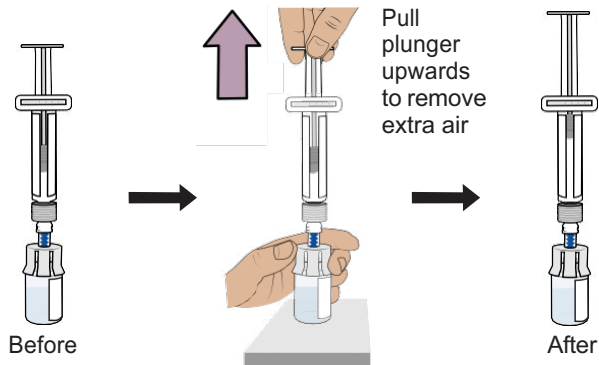

While the vial oriented upright, **gently pull the plunger upwards** to the top of the barrel but be careful not to pull the plunger out of the syringe.

**Tip:** This step only pulls extra air out of the vial to reduce the pressure in the vial and prevent medicine from spilling during the syringe removal.

## 13 Remove prefilled syringe from vial

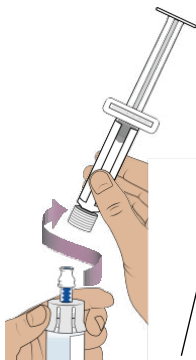

Throw away empty  
prefilled syringes

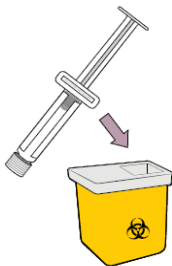

Hold the vial adaptor and unscrew  
the syringe from the vial.

Throw away the syringe in the  
sharps container.

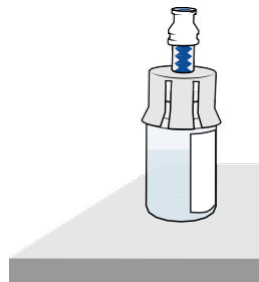

You should have a vial of  
medicine prepared and ready  
to be used in the next steps.

# Withdraw your prescribed dose (Withdraw)

For the next steps, you will need:

- Mixed vial of medicine
- Items from the Bottom Tray

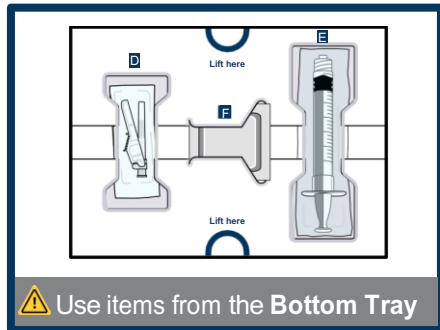

## 14 Clean top of vial adaptor

With a new alcohol wipe from the bottom tray, clean the top of the vial adaptor.

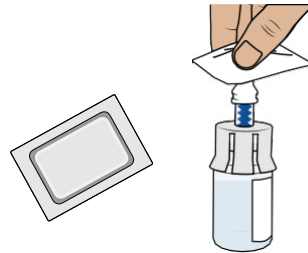

## 15 Remove empty dosing syringe from its package

Find the empty dosing syringe in the bottom tray and remove it from its package.

You will use this dosing syringe to measure out the medicine you need (based on your prescribed dose).

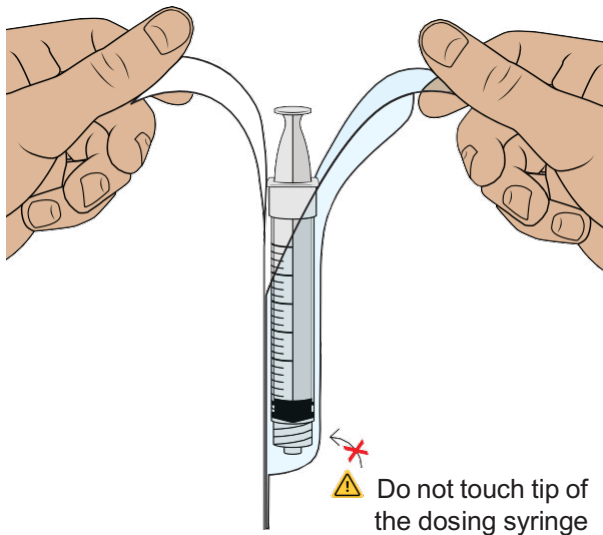

## 16 Pull air into the dosing syringe

**⚠** You must do this to make sure pressure in the vial is even and you get an accurate dose.

Hold the dosing syringe upright and pull down the plunger to **draw air into the dosing syringe**. **Stop when you get to the amount in 'mL' listed in your prescription.**

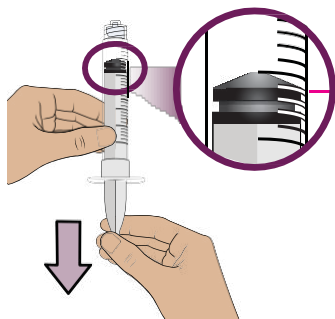

### Top rim of the plunger

Pull plunger until top rim of plunger is at your prescribed dose

**Tip:** Each line on the dosing syringe is 0.1 mL.

**17** Connect dosing syringe to the vial

While holding the vial adaptor, screw the dosing syringe on until it stops.

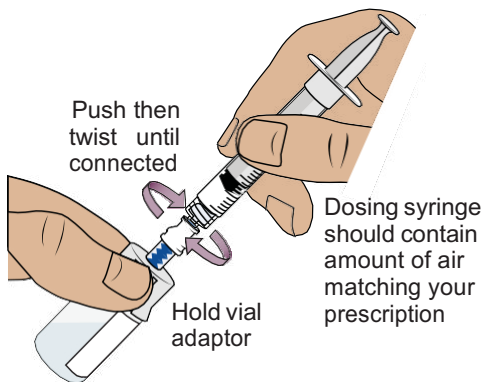

**18** Push air into vial, then flip upside down

Push the plunger all the way down to transfer all the air into the vial. Then **hold the plunger in place** with your thumb and flip the vial upside down.

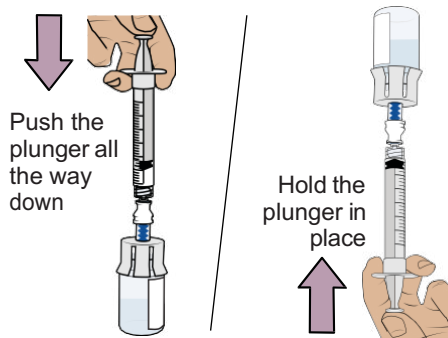

**19**

## Pull plunger back to withdraw your dose

With the vial and dosing syringe upside down, **slowly pull the plunger back**.

Stop when you get to the **amount in 'mL' listed on your prescription**.



 **Top rim of the plunger**  
Should line up with  
**your prescribed dose**

**Tip:** Each line on the dosing syringe is 0.1 mL.

**20**

## Check for air bubbles and air pockets

Check to see if there are large air bubbles or an air pocket in the syringe. You will remove extra air in the next steps.

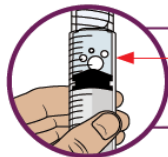

Large air bubbles

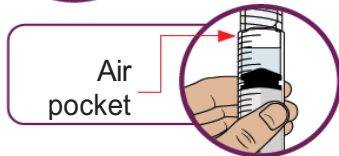

Air pocket

**21**

## Remove air bubbles and air pockets

If you see air bubbles or an air pocket, tap the side of the dosing syringe to move the air to the top.

**Slowly push the plunger up** to remove extra air.

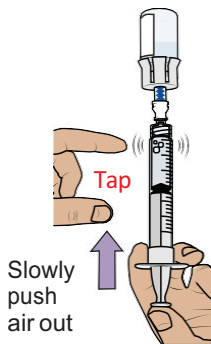

 You must remove large bubbles and air pockets to get an accurate dose

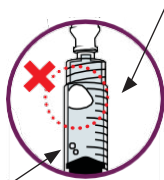

1 or 2 small bubbles are okay

**22**

## Compare amount to prescribed dose

After removing all extra air, **compare the amount to your prescribed dose.**

**If you do not have your prescribed amount in your syringe, slowly pull the plunger back again to withdraw more medicine.**



Repeat Steps 19 to 21 until you reach **your prescribed dose** and no large bubbles are visible.

## 23 Confirm your prescribed dose.

Before you continue, check to make sure you have the prescribed dose in the dosing syringe.

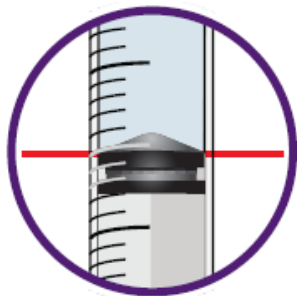

The top rim of the plunger should line up with **your prescribed dose**

**⚠ If the amount does not match your prescribed dose, repeat Steps 19 to 22.**

24

## Remove the dosing syringe from the vial and set the dosing syringe aside

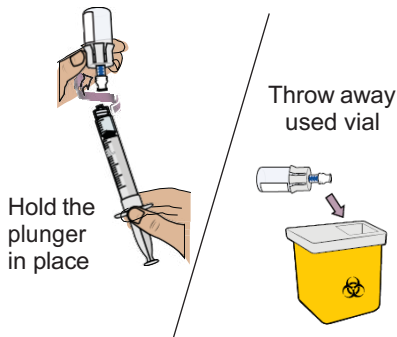

**Hold the plunger in place with one hand.** With the other hand, hold the vial adaptor and unscrew the filled dosing syringe from the vial.

Throw away the vial into the sharps container.



Place the filled dosing syringe on a clean, flat surface.



Do not touch the dosing syringe tip or let it touch any surfaces.

## 25 Attach the injection needle

 Do not touch the connection hub of the needle

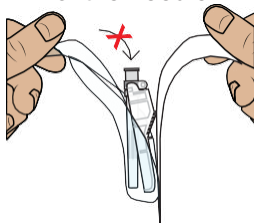

Find the needle in the bottom tray and open its package.

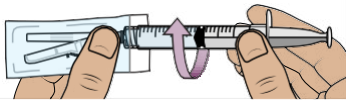

With the needle still in the package, **grip the base of the needle** and **twist on the dosing syringe** until it stops. Remove the needle package.

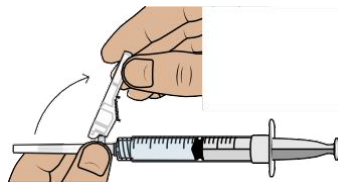

**Move the safety shield away from the needle** and toward the syringe to the angle shown. Place the dosing syringe on a clean, flat surface.

 Do not uncap the needle

## 26 Choose and clean your injection site

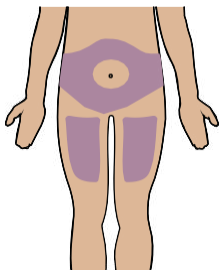

**Select an injection site** on your stomach (abdomen) or your upper thigh. If injecting on your stomach area, avoid a 5 cm area around your belly button.

Choose a different site every time you inject.

⚠ Do not inject into skin that is damaged, sore, bruised, or has red patches

⚠ Do not inject through clothes



**Clean the injection site** with a new alcohol wipe.

⚠ Do not touch the cleaned injection site again

**Now, you are ready to inject the medicine.**

# Inject your medicine (Inject)

## 27 Inject your medicine

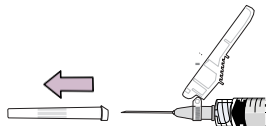

Pull the cap straight off the needle.  
Throw away the cap.

 Do not touch the plunger until ready to inject so you don't lose any medicine

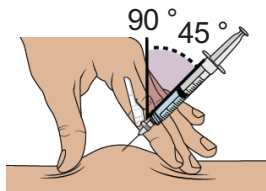

Gently **pinch and hold a fold of skin** where you will inject. Insert the needle with a **dartlike motion at a 45° to 90° angle**. This helps you inject directly under the skin (subcutaneous injection).

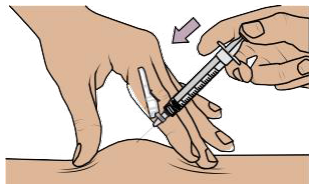

**Push** the plunger with slow, steady pressure all the way down until the dosing syringe is empty. **Confirm all the medicine has been injected.**  
You can let go of the skin fold now.

 Keep your fingers away from the needle at all times.

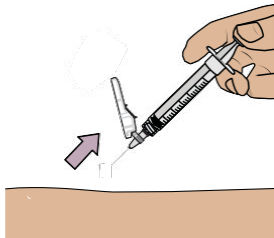

While keeping the plunger pushed in, **remove the needle from your skin** at the same angle you inserted it.

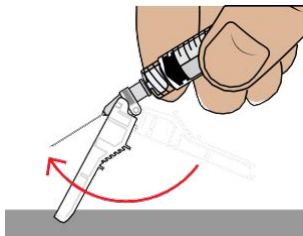

To reapply the safety shield, push the shield against a flat surface until you hear a “click” and see that the needle is covered.



Throw away the dosing syringe and used items in a sharps disposal container.

 Do not remove the needle from the dosing syringe

# How to throw away WINREVAIR

Ask your pharmacist how to throw away medicines you no longer use. These measures will help protect the environment. Make sure to follow local requirements for disposal as they may be different from the general recommendations below.

- Throw away any used vial (including any remaining WINREVAIR liquid), needle, vial and needle caps, and used syringes in a sharps disposal container.
- Do not throw away the WINREVAIR vials, syringes, or needle in your household waste.
- **Do not reuse any of the supplies.** This product is disposable and should only be used one time.
- **Important:** Always keep the sharps disposal container out of reach of children and pets.



If you do not have a sharps disposal container, you may use a household container that is:

- made of a heavy-duty plastic,
- can be closed with a tight-fitting, puncture-resistant lid, without sharp objects being able to come out,
- upright and stable during use,
- leak resistant, and
- properly labeled to warn of hazardous waste inside the container.

When your container is almost full, you will need to follow local guidelines for the right way to throw away your container.



Do not recycle your used container

# Frequently asked questions

## **What should I do if I'm bleeding from the injection site?**

Place a cotton ball or bandage on your skin right away and apply a small amount of pressure. If the bleeding does not stop, call your doctor or pharmacist right away.

## **Where can I find my prescription amount?**

Your prescription amount in 'mL' is on your prescription. Contact your doctor or pharmacist if you can't find your prescription amount.

## **What should I do if I accidentally get some medicine on my skin or my work surface?**

Wash the area thoroughly with soap and water right away.

## **What should I do if I'm not sure I administered my prescribed dose correctly?**

Call your doctor or pharmacist.

### **What should I do if the plunger of my dosing syringe moves automatically when I try to withdraw medicine from the vial?**

Don't worry if your plunger moves slightly on its own when you are filling your dosing syringe with medicine.

With one hand, **hold the plunger in place to stop the plunger from moving.**

With the other hand, unscrew the vial from the dosing syringe.

Once unscrewed, it is safe to let go of the plunger.

You can avoid this automatic plunger movement by pushing air into the vial before filling your dosing syringe with medicine. Refer to Steps 16 to 23 for detailed instructions.

### **What should I do if my pack parts are damaged or compromised (for example, discoloured, cloudy, or has particles)?**

If your pack parts are damaged or compromised, do not use it. Call your doctor or pharmacist to get a new pack.

# Frequently asked questions

## **What should I do if my medicine does not turn clear after mixing and swirling?**

Do not use the medicine if you have swirled the medicine vial for about 2 minutes and let it stand for another 3 minutes, but your medicine vial remains cloudy or has clumps, powder, or foreign particles. Call your doctor or pharmacist to get a new pack.

## **What should I do if the sterile water won't come out of the prefilled syringe?**

Check that the vial adaptor is attached to the vial securely. If not, hold the vial and press the vial adaptor down firmly to make sure the vial adaptor punctures the vial rubber stopper.

## **What should I do if I dropped my pack components?**

Do not use if any items are damaged. If you are unsure, call your doctor or pharmacist to get a new pack.

### **Can I use my pack that has been left out of the refrigerator?**

If the unused pack has been out of the refrigerator for an extended period of time, please contact your doctor or pharmacist before proceeding.

### **Do I need to use mixed medicine right away?**

We recommend you inject the medicine right after mixing but no later than 4 hours after mixing. If it has been more than 4 hours, throw away unused mixed medicine. If you have questions or are unsure about the process, please contact your doctor or pharmacist.

### **How can I get help preparing and giving my injection?**

If you have questions about how to give WINREVAIR the correct way or need more information, you can call your doctor or pharmacist.

For any other information about this medicine, please contact your doctor or pharmacist, or the local representative of the Marketing Authorisation Holder.

This booklet was last revised in November 2025.

Tracking Number: CCIFU1-MK7962-I-082023

Copyright © 2025 Merck & Co., Inc., Rahway, NJ, USA, and its affiliates.  
All rights reserved.

**IMPORTANT: read this booklet before use**

# Instructions for Use

**WINREVAIR<sup>®</sup>** sotatercept

45 mg powder and solvent for solution for injection (2 vial - pack)

60 mg powder and solvent for solution for injection (2 vial - pack)

This booklet contains instructions on how to prepare and inject Winrevair powder and solvent for solution for injection. The package leaflet, also provided in the pack, contains all the important information for you.

Dose based on patient weight

**For subcutaneous (SC) injection only** (inject directly under the skin)

Important

Mix

Combine

Withdraw

Inject

# In this booklet (Important):

Important information for healthcare professionals .....	3
Before you start .....	4
Get to know the parts of your pack .....	6
Important information to know before injecting.....	8
Storing your pack.....	9
Get started .....	10
● <b>Mix</b> powdered medicine into liquid form.....	12
● <b>Combine</b> medicine from both vials .....	24
● <b>Withdraw</b> your prescribed dose .....	30
● <b>Inject</b> your medicine .....	36
How to throw away WINREVAIR .....	38
Frequently asked questions .....	40



## Important information for healthcare professionals

A healthcare professional will provide training regarding proper preparation and administration of WINREVAIR following this “Instructions for Use” (IFU) booklet step-by-step, and decide whether a patient or caregiver is capable of preparing and administering WINREVAIR independently.

Make sure the patient or caregiver can do the following correctly:

1. Reconstitute the medicine
2. Combine medicine from both vials
3. Measure the correct amount of medicine according to patient’s prescription
4. Select and prepare a proper injection site
5. Inject the medicine subcutaneously

## Before you start:



### **Read this booklet**

Read these instructions from start to finish before you use WINREVAIR for the first time and before every administration. There may be new information.



### **Start with your doctor or nurse**

Do not use WINREVAIR until your doctor or nurse has shown you or your caregiver the right way to prepare and inject it. Your doctor or nurse should show you how to inject WINREVAIR before you use it for the first time.



### **Questions?**

If you have questions about how to give Winrevair the right way or need more information, talk to your doctor, pharmacist, or nurse.



## How to use this product

Before injecting, make sure you read the full instructions in this booklet to get the right dose of medicine.

- **Mix** medicine in vial 1
- **Mix** medicine in vial 2
- **Combine** medicine from both vials
- **Withdraw** your prescribed dose from vial 2
- Then, you'll be ready to **inject** your medicine

Proceed to the next pages for step-by-step directions.

# Get to know the parts of your pack

## Top Tray

Use to mix the medicine

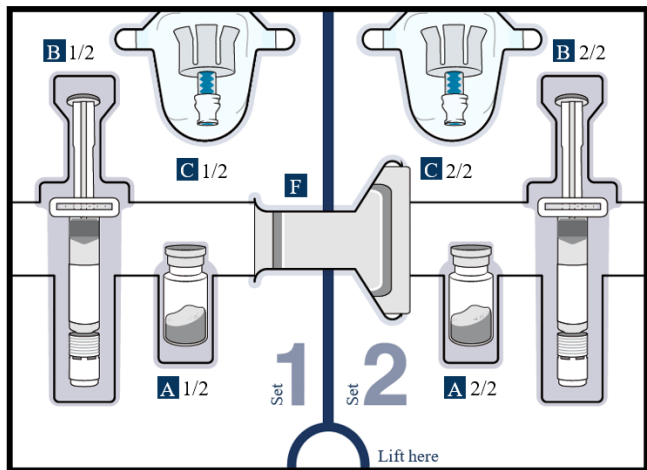

**A - 2 Vials of WINREVAIR medicine powder**



**B - 2 Prefilled syringes (solvent) with sterile water to mix medicine powder into liquid**



**C - 2 Vial adaptors to connect the vial and syringe**

## Bottom Tray

Use to **inject** the medicine

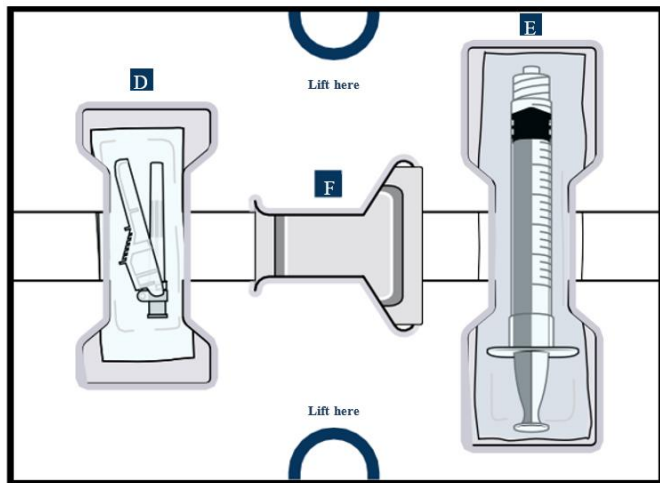

**D - 1 Needle** for injection

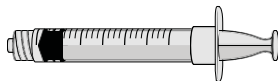

**E - 1 Empty dosing syringe** to measure, withdraw, and inject your medicine



**F - 8 Alcohol wipes**  
(4 on each tray)

# Important information to know before injecting

- You must mix this product before using it. Make sure the medicine powder in the vial is completely dissolved when you inject.
- **Check your prescribed dose (amount in 'mL') each time you use the product. Your prescribed dose may change.**
- Use only the supplies that are in the pack to prepare your prescribed dose.
- Do not open the pack or mix the medicine until you are ready to use it.
- **Do not reuse any of the supplies.** After your injection, dispose of any unused medicine and used supplies according to the local requirements. See pages 38-39 for more information.

## Storing your pack

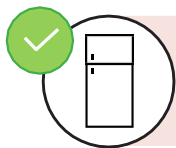

Store the entire pack in the refrigerator, but do not freeze.

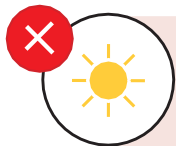

Keep the medicine and supplies in the pack and away from light.



Keep pack out of the sight and reach of children and pets.

# Get started

Any patient or caregiver who is to prepare and inject WINREVAIR must first be trained and deemed capable of independent administration of WINREVAIR by a healthcare professional.

## 1 Check WINREVAIR product and expiry date

Remove the WINREVAIR pack from the refrigerator.

- ✓ **Check the expiry date and look for any signs of damage** on the pack or in the supplies.

 If expired or damaged, do not use. Talk to your doctor or pharmacist immediately to get a new pack.

- ✓ **Check that you have the medicine** that your doctor prescribed.

**2**

## Let your pack come to room temperature, gather supplies, and wash your hands

Wait 15 minutes to allow your pack to warm to room temperature.

Cold medicine is more painful to inject.

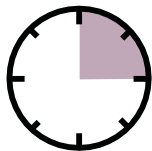

**15 minutes**

Along with your pack, gather these items and find a clean, flat surface where you will prepare and inject your dose.



Sharps disposal container

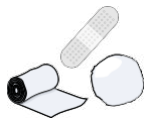

Gauze, cotton ball or bandage

Wash your hands with soap and water.

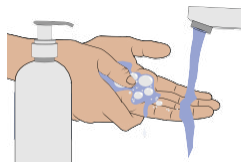

# Mix powdered medicine into liquid form (Mix)

Start with the Top Tray

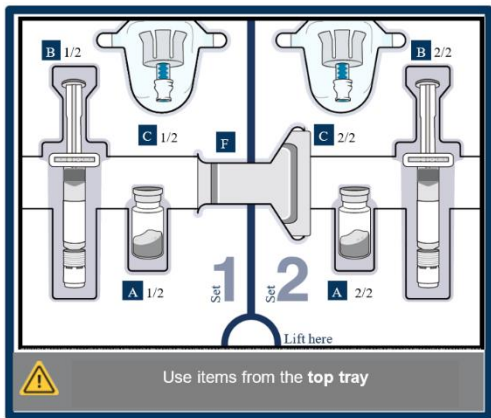

3

Remove vial 1, prefilled syringe 1, and vial adaptor 1 from the pack

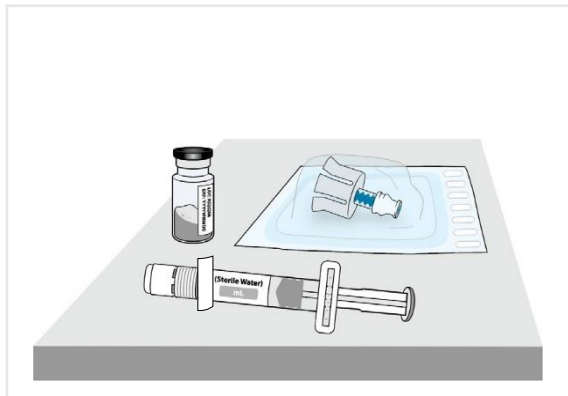

## 4a Check the medicine and the vial

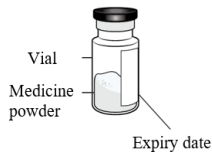

- ✓ Not damaged?
- ✓ No visible particle?
- ✓ Not expired?

Check the vial label to **confirm the medicine is not expired.**

Visually inspect the medicine powder. It should be white to off-white and may look like a whole or broken up cake.

**⚠** Do not use if expired, damaged, or you can see particles in it.

## 4b Remove plastic cap and clean the vial

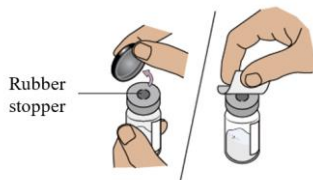

Flip off the plastic cap and **clean the rubber stopper on top of the vial** with an alcohol wipe.

**⚠** Do not use if vial cap is missing

**⚠** Do not touch the cleaned rubber stopper

Set vial aside on a clean, flat surface.

## 5a Align vial adaptor to vial

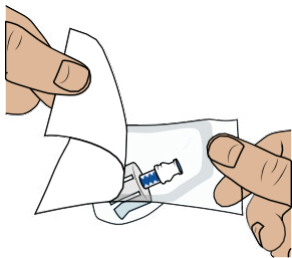

Peel open the vial adaptor package and remove it from its package.



To attach the vial adaptor:

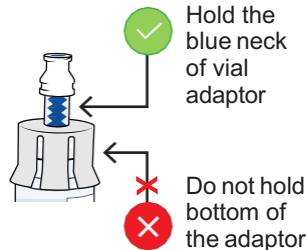

**Hold the blue neck of the adaptor** and align the vial adaptor on top of the vial.

 Do not touch the inside of the vial adaptor to keep it clean and avoid sharps.

## 5b Attach vial adaptor to vial

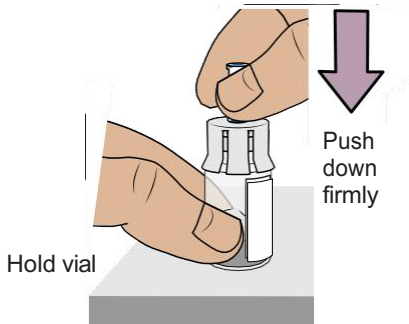

Hold the vial with one hand. **Push the vial adaptor down firmly** so it snaps in place (you may feel some resistance).

## 5c Clean vial adaptor

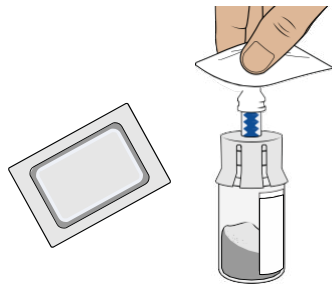

Clean the top of the vial adaptor with an alcohol wipe.

## 6 Check prefilled syringe

Confirm the product is not expired. Visually inspect that the sterile water inside the prefilled syringe is clear.

- ✓ Not damaged?
- ✓ Clear?
- ✓ No particles?
- ✓ Not expired?

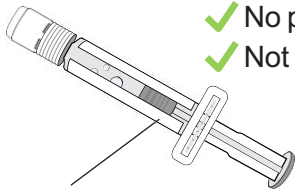

Expiry Date

- ⚠ Do not use if you see any clumps, particles, discolouration, or product is expired

## 7 Break off prefilled syringe white cap

Break off the prefilled syringe cap along the perforation.

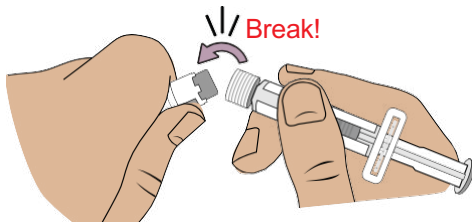

- ⚠ Do not touch the tip of the prefilled syringe
- ⚠ Do not push the plunger; it may spill the sterile water

## 8 Connect prefilled syringe to vial adaptor

Now, pick up the medicine vial with the vial adaptor attached.

**Align the prefilled syringe tip on the blue circle of the vial adaptor.**

**Push and twist the prefilled syringe onto the vial adaptor until you cannot turn further.** While twisting, be sure to hold onto the vial adaptor.

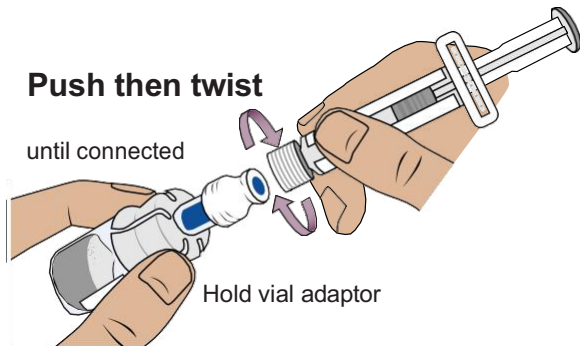

**⚠** Do not push the plunger; it may spill the sterile water

## 9

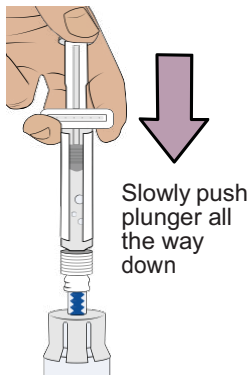
**Transfer sterile water from prefilled syringe to vial**

*Slowly* push the plunger all the way down to transfer all the sterile water into the vial (the plunger will move up; this is normal).

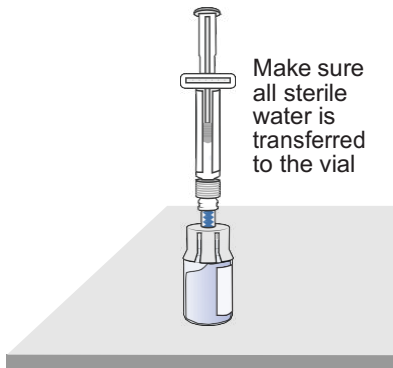

Leave the prefilled syringe attached to the vial and set aside on a flat surface.

## 10 Prepare vial 2, prefilled syringe 2, and vial adaptor 2

Remove **vial 2**, **prefilled syringe 2**, and **vial adaptor 2** from the pack.

### **Important:**

Turn back to Page 13 and  
repeat Steps **4** to **9**  
to **prepare vial 2**.

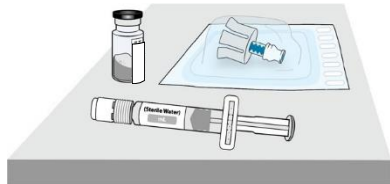

**Stop and check if you have both vial 1 and vial 2 prepared.**  
You need both vials prepared before you can continue to  
Step 11.

## 11

## Swirl to mix medicine

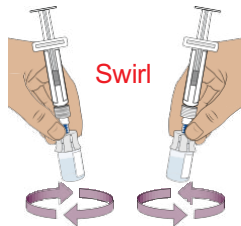

 Do not shake the vials

Hold one prefilled syringe in each hand and **gently swirl both vials in a circular motion** until the powder is fully dissolved. This may take up to **2 minutes**. **Do not shake or agitate vigorously.**

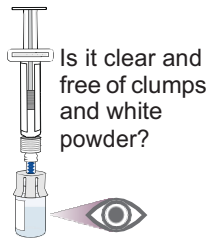

When the medicine is mixed well, it should be clear. If not, repeat this step until it is clear.

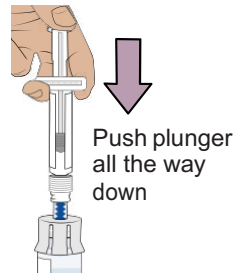

For each vial, **press the plunger down** again to make sure all the liquid is in the vial since some liquid could have moved back into the syringe (the plunger will move up; this is normal).

**12**

## Wait for the bubbles to go away

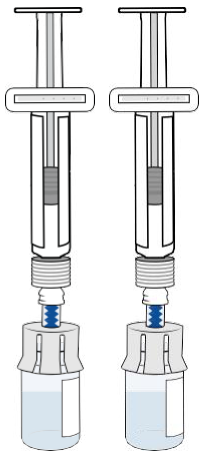

**3 minutes**

**Set both vials aside for bubbles to go away.**  
This may take up to 3 minutes.



Before you continue, make sure the medicine in the vial:

- ✓ Is clear to opalescent and colourless to slightly brownish-yellow
- ✓ Does not have clumps or powder
- ✓ Does not have large bubbles

It is okay to have slight foam (small bubbles) around the edges of the vial.

## 13 Prepare vial by removing extra air

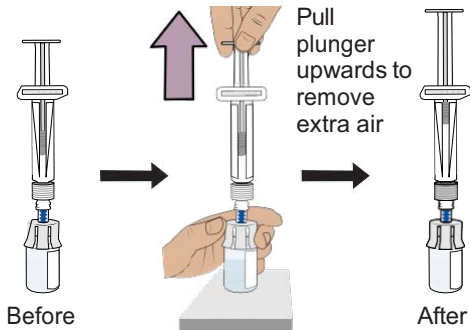

Start with either vial. While having the vial oriented upright, **gently pull the plunger upwards** to the top of the barrel but be careful not to pull the plunger out of the syringe.

**Tip:** This step only pulls extra air out of the vial to reduce the pressure in the vial and prevent medicine from spilling during the syringe removal.



### Important:

Perform this step for **both** vials. Stop and check you have **both** vials prepared before continuing.

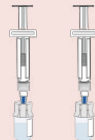

## 14 Remove prefilled syringe from vial

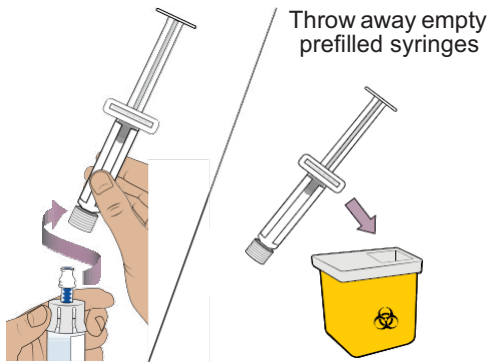

Hold the vial adaptors and unscrew **both** syringes from the vials.

Throw away **both** syringes in the sharps container.

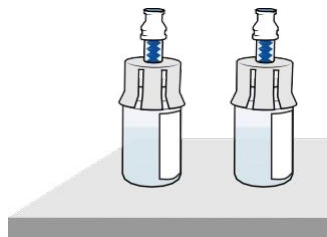

You should have 2 vials of medicine prepared and ready to be combined in the next steps.

# Combine medicine from both vials (Combine)

For the next steps, you will need:

- Mixed vial 1 and vial 2
- Items from the Bottom Tray

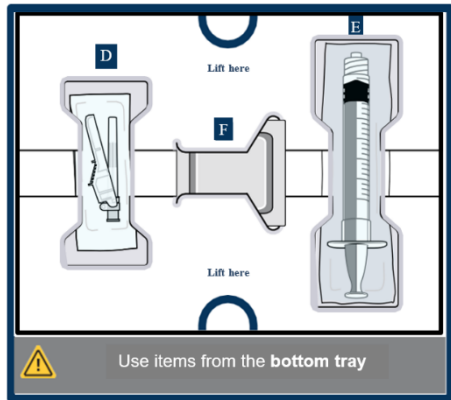

## 15 Clean top of both vial adaptors

With 2 new alcohol wipes from the bottom tray, clean the top of the vial adaptors.

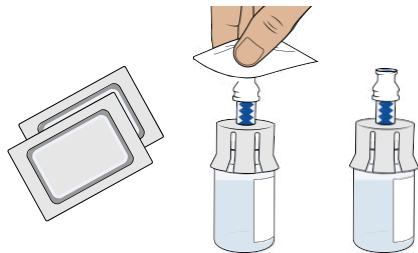

## 16 Remove empty dosing syringe from its package

Find the empty dosing syringe in the bottom tray and remove it from its package.

You will use this dosing syringe to measure out the medicine you need (based on your prescribed dose).

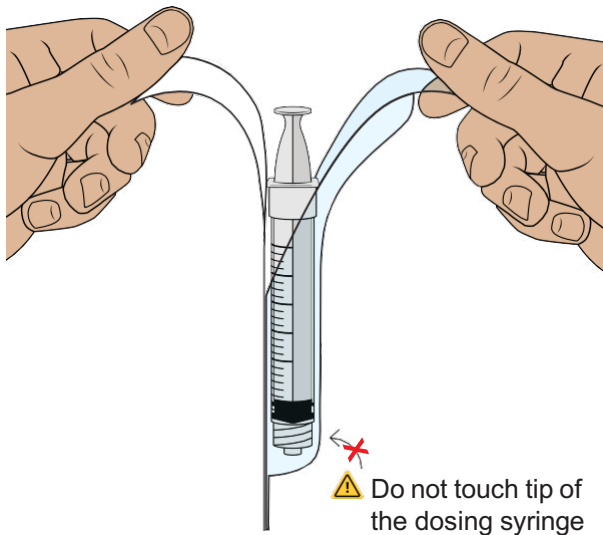

## 17 Pull air into the dosing syringe

**⚠** You must do this to make sure pressure in the vial is even and you get an accurate dose.

Hold the dosing syringe upright and pull down the plunger to **draw in 1.5 mL of air.**

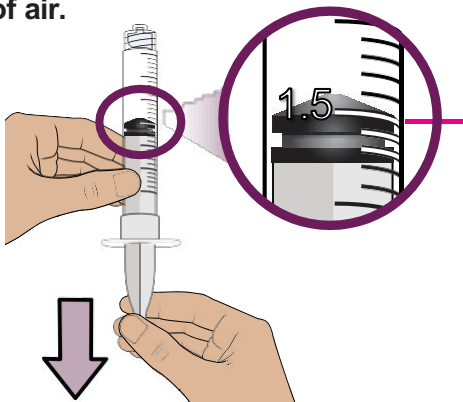

**Top rim  
of the plunger**

Pull plunger until top rim of plunger is at 1.5 mL

**Tip:** Each line on the dosing syringe is 0.1 mL.

## 18 Connect dosing syringe to one of the vials

While holding the vial adaptor, screw the dosing syringe on until it stops.

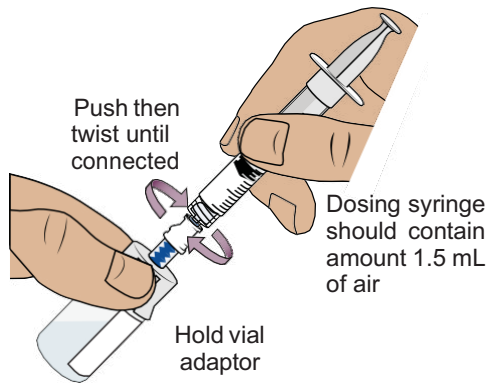

## 19 Push air into vial, then flip upside down

Push the plunger all the way down to transfer all the air into the vial. Then **hold the plunger in place** with your thumb and flip the vial upside down.

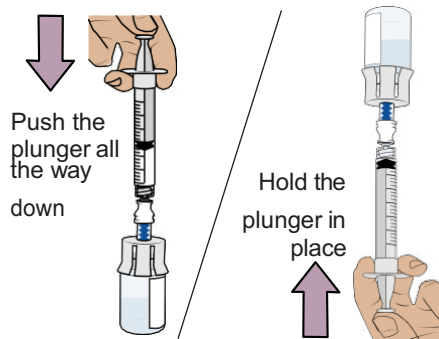

**20**

## Drain all the medicine from 1<sup>st</sup> vial

Slowly pull the plunger back. **Stop at 1.5 mL.**

This will make sure all the medicine in the vial is in the dosing syringe.



 Do not pull the plunger beyond 1.5 mL. **Stop at 1.5 mL**

 Be careful not to pull the plunger out of the dosing syringe

**21**

## Remove 1<sup>st</sup> vial from the dosing syringe

Hold the vial adaptor and unscrew the filled dosing syringe from the vial.

Throw away the **empty** vial into the sharps container.

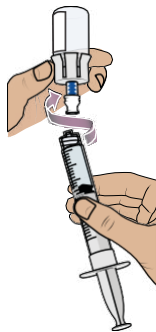

Throw away empty vial

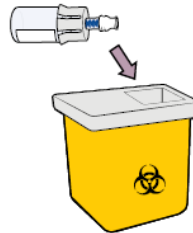

**22**

## Connect the dosing syringe to the 2<sup>nd</sup> vial

While holding the vial adaptor of the 2<sup>nd</sup> vial, screw the partially filled dosing syringe onto the vial adaptor until it stops.

 Do not touch the plunger; it may spill medicine

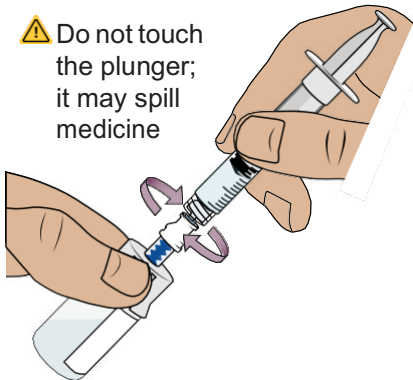
**23**

## Push all the medicine into the 2<sup>nd</sup> vial, then flip upside down

*Slowly* push the plunger all the way down to transfer **all of the medicine into the vial** to ensure dose accuracy. This combines the medicine from both vials.

Then **hold the plunger in place** with your thumb and flip the vial upside down.

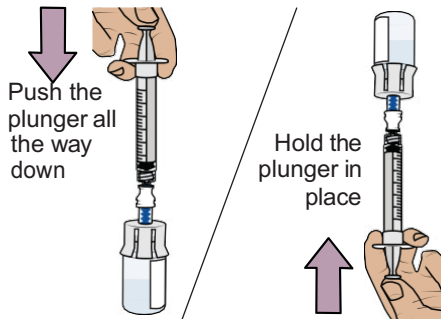

# Withdraw your prescribed dose (Withdraw)

## 24 Pull plunger back to withdraw your dose

With the vial and dosing syringe upside down, **slowly pull the plunger back**.

Stop when you get to the **amount in 'mL' listed on your prescription**.

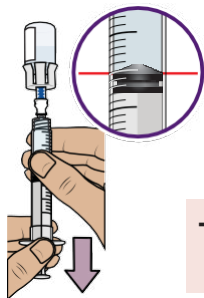

 **Top rim of plunger should line up with your prescribed dose**

**Tip:** Each line on the dosing syringe is 0.1 mL.

## 25 Check for air bubbles and air pockets

Check to see if there are large air bubbles or an air pocket in the syringe. You will remove extra air in the next steps.

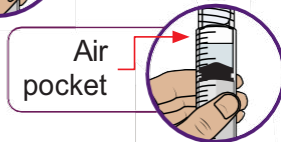
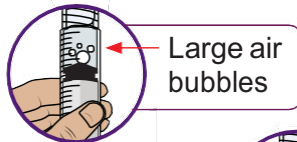

**26**

## Remove air bubbles and air pockets

If you see air bubbles or an air pocket, tap the side of the dosing syringe to move the air to the top.

**Slowly push the plunger up** to remove extra air.

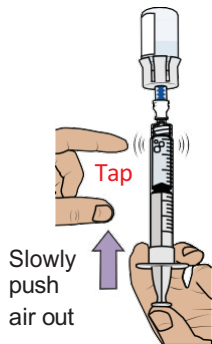

**⚠** You must remove large bubbles and air pockets to get an accurate dose



1 or 2 small bubbles are okay

**27**

## Compare amount to prescribed dose

After removing all extra air, **compare the amount to your prescribed dose.**

**If you do not have your prescribed amount in your syringe, slowly pull the plunger back again** to withdraw more medicine.



Repeat Steps 24 to 26 until you reach **your prescribed dose** and no large bubbles are visible.

## 28 Confirm your prescribed dose

Before you continue, check to make sure you have the prescribed dose in the dosing syringe.

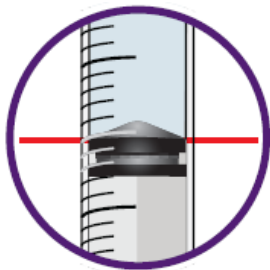

The top rim of the plunger should line up with **your prescribed dose**

**⚠ If the amount does not match your prescribed dose, repeat Steps 24 to 27.**

29

## Remove the dosing syringe from the vial and set the dosing syringe aside



Hold the plunger in place

Throw away used vial



**Hold the plunger in place with one hand.** With the other hand, hold the vial adaptor and unscrew the filled dosing syringe from the vial.

Throw away the vial into the sharps container.

Place the filled dosing syringe on a clean, flat surface.



**⚠** Do not touch the dosing syringe tip or let it touch any surfaces

## 30 Attach the injection needle

 Do not touch the connection hub of the needle

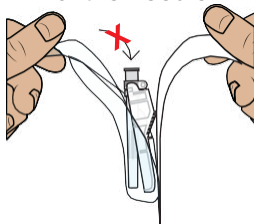

Find the needle in the bottom tray and open its package.

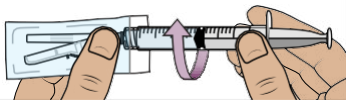

With the needle still in the package, **grip the base of the needle** and **twist on the dosing syringe** until it stops. Remove the needle package.



**Move the safety shield away from the needle** and toward the syringe to the angle shown. Place the dosing syringe on a clean, flat surface.

 Do not uncap the needle

## 31 Choose and clean your injection site

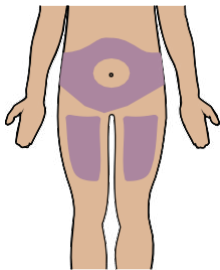

**Select an injection site** on your stomach (abdomen) or your upper thigh. If injecting on your stomach area, avoid a 5 cm area around your belly button.

Choose a different site every time you inject.

⚠ Do not inject into skin that is damaged, sore, bruised, or has red patches

⚠ Do not inject through clothes

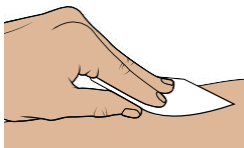

**Clean the injection site** with a new alcohol wipe.

⚠ Do not touch the cleaned injection site again

**Now, you are ready to inject the medicine.**

# Inject your medicine

## 32 Inject your medicine (Inject)

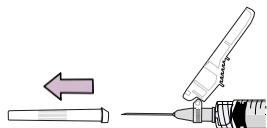

Pull the cap straight off the needle.  
Throw away the cap.

 Do not touch the plunger until ready to inject so you don't lose any medicine

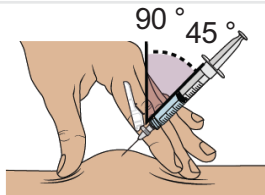

Gently **pinch and hold a fold of skin** where you will inject. Insert the needle with a **dartlike motion at a 45° to 90° angle**. This helps you inject directly under the skin (subcutaneous injection).

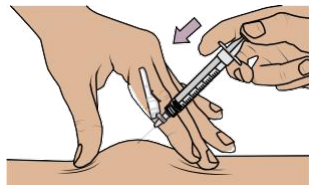

**Push** the plunger with slow, steady pressure all the way down until the dosing syringe is empty. **Confirm all the medicine has been injected.** You can let go of the skin fold now.

 Keep your fingers away from the needle at all times.

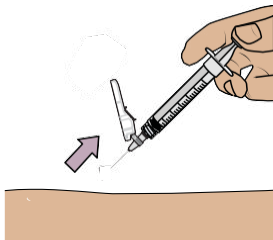

While keeping the plunger pushed in, **remove the needle from your skin** at the same angle you inserted it.

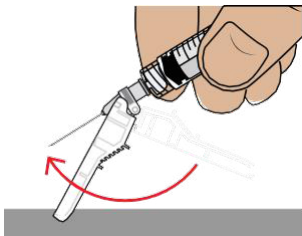

To reapply the safety shield, push the shield against a flat surface until you hear a “click” and see that the needle is covered.



Throw away the dosing syringe and used items in a sharps disposal container.

 Do not remove the needle from the dosing syringe

# How to throw away WINREVAIR

Ask your pharmacist how to throw away medicines you no longer use. These measures will help protect the environment. Make sure to follow local requirements for disposal as they may be different from the general recommendations below:

- Throw away any used vial (including any remaining WINREVAIR liquid), needle, vial and needle caps, and used syringes in a sharps disposal container.
- Do not throw away the WINREVAIR vials, syringes, or needle in your household waste.
- **Do not reuse any of the supplies.** This product is disposable and should only be used one time.
- **Important:** Always keep the sharps disposal container out of reach of children and pets.



If you do not have a sharps disposal container, you may use a household container that is:

- made of a heavy-duty plastic,
- can be closed with a tight-fitting, puncture-resistant lid, without sharp objects being able to come out,
- upright and stable during use,
- leak resistant, and
- properly labelled to warn of hazardous waste inside the container.

When your container is almost full, you will need to follow local guidelines for the right way to throw away your container.



Do not recycle your used container

# Frequently asked questions

## **What should I do if I'm bleeding from the injection site?**

Place a cotton ball or bandage on your skin right away and apply a small amount of pressure. If the bleeding does not stop, call your doctor or pharmacist right away.

## **Where can I find my prescription amount?**

Your prescription amount in 'mL' is on your prescription. Contact your doctor or pharmacist if you can't find your prescription amount.

## **What should I do if I accidentally get some medicine on my skin or my work surface?**

Wash the area thoroughly with soap and water right away.

## **What should I do if I'm not sure I administered my prescribed dose correctly?**

Call your doctor or pharmacist.

### **What should I do if the plunger of my dosing syringe moves automatically when I try to withdraw medicine from the vial?**

Don't worry if your plunger moves slightly on its own when you are filling your dosing syringe with medicine.

With one hand, **hold the plunger in place to stop the plunger from moving.**

With the other hand, unscrew the vial from the dosing syringe.

Once unscrewed, it is safe to let go of the plunger.

You can avoid this automatic plunger movement by pushing air into the vial before filling your dosing syringe with medicine. Refer to Steps 17 to 28 for detailed instructions.

### **What should I do if my pack parts are damaged or compromised (for example, discoloured, cloudy, or has particles)?**

If your pack parts are damaged or compromised, do not use it. Call your doctor or pharmacist to get a new pack.

# Frequently asked questions

## **What should I do if my medicine does not turn clear after mixing and swirling?**

Do not use the medicine if you have swirled the medicine vial for about 2 minutes and let it stand for another 3 minutes, but your medicine vial remains cloudy or has clumps, powder, or foreign particles. Call your doctor or pharmacist to get a new pack.

## **What should I do if the sterile water won't come out of the prefilled syringe?**

Check that the vial adaptor is attached to the vial securely. If not, hold the vial and press the vial adaptor down firmly to make sure the vial adaptor punctures the vial rubber stopper.

## **What should I do if I dropped my pack components?**

Do not use if any items are damaged. If you are unsure, call your doctor or pharmacist to get a new pack.

### **Can I use my pack that has been left out of the refrigerator?**

If the unused pack has been out of the refrigerator for an extended period of time, please contact your doctor or pharmacist before proceeding.

### **Do I need to use mixed medicine right away?**

We recommend you inject the medicine right after mixing, but no later than 4 hours after mixing. If it has been more than 4 hours, throw away unused mixed medicine. If you have questions or are unsure about the process, please contact your doctor or pharmacist.

### **How can I get help preparing and giving my injection?**

If you have questions about how to give WINREVAIR the correct way or need more information, you can call your doctor or pharmacist.

For any other information about this medicine, please contact your doctor or pharmacist, or the local representative of the Marketing Authorisation Holder.

This booklet was last revised in November 2025.  
Tracking Number: CCIFU2-MK7962-I-082023

Copyright © 2025 Merck & Co., Inc., Rahway, NJ, USA, and its affiliates.  
All rights reserved.