

Resyniv[®] (Denosumab)

1. NAME OF THE MEDICINAL PRODUCT

Resyniv[®] 60mg/ml Solution for Injection In Pre-filled Syringe

2. QUALITATIVE AND QUANTITATIVE COMPOSITION

Each pre-filled syringe contains 60 mg of denosumab in 1 mL of solution (60 mg/mL).

Denosumab is a human monoclonal IgG2 antibody produced in a mammalian cell line (Chinese hamster ovary cells) by recombinant DNA technology.

Excipient with known effect

This medicine contains 46 mg sorbitol in each mL of solution. For the full list of excipients, see section 6.1.

3. PRODUCT DESCRIPTION

Solution for injection in pre-filled syringe.

Clear, colourless to yellowish liquid.

Resyniv[®] is a biosimilar medicinal product of Prolia[®].

4. CLINICAL PARTICULARS

4.1 Therapeutic indications

Postmenopausal osteoporosis

Resyniv[®] is indicated for the treatment of osteoporosis in postmenopausal women at increased risk of fracture. In postmenopausal women with osteoporosis, Resyniv[®] increases bone mineral density (BMD) and reduces the incidence of hip, vertebral and non-vertebral fractures.

Bone loss in patients undergoing hormone ablation for cancer

Resyniv[®] is indicated for the treatment of bone loss in patients undergoing hormone ablation for prostate or aromatase inhibitor treatment for breast cancer. In patients with prostate cancer, Resyniv[®] reduces the incidence of vertebral fractures.

Male osteoporosis

Resyniv[®] is indicated as a treatment to increase bone mass in men with osteoporosis at increased risk of fracture.

Glucocorticoid-induced osteoporosis

Treatment of glucocorticoid-induced osteoporosis in men and women at high risk of fracture who are either initiating or continuing systemic glucocorticoids in a daily dosage equivalent to 7.5 mg or greater of prednisone and expected to remain on glucocorticoids for at least 6 months.

4.2 Posology and method of administration

Administration

For subcutaneous use.

Administration should be performed by an individual who has been adequately trained in injection techniques.

The instructions for use, handling and disposal are given in section 6.6.

Dosage

The recommended dose of Resyniv[®] is a single subcutaneous injection of 60 mg administered once every 6 months.

Patients should receive calcium and vitamin D supplements whilst undergoing treatment.

Populations

Elderly (age ≥ 65)

No dose adjustment is required in elderly patients.

Renal impairment

No dose adjustment is required in patients with renal impairment (see section 4.4 for recommendations relating to monitoring of calcium).

No data is available in patients with long-term systemic glucocorticoid therapy and severe renal impairment (GFR < 30 mL/min).

Hepatic impairment

The safety and efficacy of Resyniv[®] have not been studied in patients with hepatic impairment (see section 5.2).

Paediatric population

Resyniv[®] should not be used in children aged < 18 years because of safety concerns of serious hypercalcaemia, and potential inhibition of bone growth and lack of tooth eruption (see sections 4.4 and 5.3). Currently available data for children aged 2 to 17 years are described in sections 5.1 and 5.2.

4.3 Contraindications

Hypocalcaemia (see section 4.4).

Hypersensitivity to the active substance or to any of the excipients listed in section 6.1.

4.4 Special warnings and precautions for use

Traceability

In order to improve the traceability of biological medicinal products, the name and the batch number of the administered product should be clearly recorded.

Calcium and vitamin D supplementation

Adequate intake of calcium and vitamin D is important in all patients.

Precautions for use

Hypocalcaemia

It is important to identify patients at risk for hypocalcaemia. Hypocalcaemia must be corrected by adequate intake of calcium and vitamin D before initiating therapy. Clinical monitoring of calcium levels is recommended before each dose and, in patients predisposed to hypocalcaemia within two

weeks after the initial dose. If any patient presents with suspected symptoms of hypocalcaemia during treatment (see section 4.8 for symptoms) calcium levels should be measured. Patients should be encouraged to report symptoms indicative of hypocalcaemia.

In the post-marketing setting, severe symptomatic hypocalcaemia (-resulting in hospitalization, life-threatening events, and fatal cases) has been reported. While most cases occurring in the first weeks of initiating therapy, it has also occurred later.

Concomitant glucocorticoid treatment is an additional risk factor for hypocalcaemia.

Renal impairment

Patients with severe renal impairment (creatinine clearance < 30 mL/min) or receiving dialysis are at greater risk of developing hypocalcaemia. The risks of developing hypocalcaemia and accompanying parathyroid hormone elevations increase with increasing degree of renal impairment. Severe and fatal cases have been reported. Adequate intake of calcium, vitamin D and regular monitoring of calcium is especially important in these patients, see above.

Skin infections

Patients receiving denosumab may develop skin infections (predominantly cellulitis) leading to hospitalisation (see section 4.8). Patients should be advised to seek prompt medical attention if they develop signs or symptoms of cellulitis.

Osteonecrosis of the jaw (ONJ)

ONJ has been reported rarely in patients receiving denosumab for osteoporosis (see section 4.8).

The start of treatment/new treatment course should be delayed in patients with unhealed open soft tissue lesions in the mouth. A dental examination with preventive dentistry and an individual benefit- risk assessment is recommended prior to treatment with denosumab in patients with concomitant risk factors.

The following risk factors should be considered when evaluating a patient's risk of developing ONJ:

- potency of the medicinal product that inhibits bone resorption (higher risk for highly potent compounds), route of administration (higher risk for parenteral administration) and cumulative dose of bone resorption therapy.
- cancer, co-morbid conditions (e.g. anaemia, coagulopathies, infection), smoking.
- concomitant therapies: corticosteroids, chemotherapy, angiogenesis inhibitors, radiotherapy to head and neck.
- poor oral hygiene, periodontal disease, poorly fitting dentures, history of dental disease, invasive dental procedures (e.g. tooth extractions).

All patients should be encouraged to maintain good oral hygiene, receive routine dental check-ups, and immediately report any oral symptoms such as dental mobility, pain or swelling or non-healing of sores or discharge during treatment with denosumab. While on treatment, invasive dental procedures should be performed only after careful consideration and be avoided in close proximity to denosumab administration.

The management plan of the patients who develop ONJ should be set up in close collaboration between the treating physician and a dentist or oral surgeon with expertise in ONJ. Temporary interruption of treatment should be considered until the condition resolves and contributing risk factors are mitigated where possible.

Osteonecrosis of the external auditory canal

Osteonecrosis of the external auditory canal has been reported with denosumab. Possible risk factors for osteonecrosis of the external auditory canal include steroid use and chemotherapy and/or local risk factors such as infection or trauma. The possibility of osteonecrosis of the external auditory canal

should be considered in patients receiving denosumab who present with ear symptoms including chronic ear infections.

Atypical fractures of the femur

Atypical femoral fractures have been reported in patients receiving denosumab (see section 4.8). Atypical femoral fractures may occur with little or no trauma in the subtrochanteric and diaphyseal regions of the femur. Specific radiographic findings characterize these events. Atypical femoral fractures have also been reported in patients with certain co-morbid conditions (e.g. vitamin D deficiency, rheumatoid arthritis, hypophosphatasia) and with use of certain medicinal products (e.g. bisphosphonates, glucocorticoids, proton pump inhibitors). These events have also occurred without antiresorptive therapy. Similar fractures reported in association with bisphosphonates are often bilateral; therefore, the contralateral femur should be examined in denosumab treated patients who have sustained a femoral shaft fracture. Discontinuation of denosumab therapy in patients suspected to have an atypical femur fracture should be considered pending evaluation of the patient based on an individual benefit risk assessment. During denosumab treatment, patients should be advised to report new or unusual thigh, hip, or groin pain. Patients presenting with such symptoms should be evaluated for an incomplete femoral fracture.

Long-term antiresorptive treatment

Long-term antiresorptive treatment (including both denosumab and bisphosphonates) may contribute to an increased risk for adverse outcomes such as osteonecrosis of the jaw and atypical femur fractures due to significant suppression of bone remodeling (see section 4.2).

Concomitant treatment with other denosumab-containing medicinal products

Patients being treated with denosumab should not be treated concomitantly with other denosumab containing medicinal products (for prevention of skeletal related events in adults with bone metastases from solid tumours).

Hypercalcaemia in paediatric patients

Biosimilar should not be used in paediatric patients (age < 18). Serious hypercalcaemia has been reported. Some clinical trial cases were complicated by acute renal injury.

Multiple vertebral fractures (MVF) following discontinuation of Denosumab treatment

Multiple vertebral fractures (MVF) may occur following discontinuation of treatment with Denosumab, particularly in patients with a history of vertebral fracture. Advise patients not to interrupt Denosumab therapy without their physician's advice. Evaluate the individual benefit/risk before discontinuing treatment with Denosumab. If Denosumab treatment is discontinued, consider transitioning to an alternative antiresorptive therapy.

Warning for excipients

This medicine contains 46 mg sorbitol in each mL of solution. The additive effect of concomitantly administered products containing sorbitol (or fructose) and dietary intake of sorbitol (or fructose) should be taken into account.

This medicinal product contains less than 1 mmol sodium (23 mg) per 60 mg that is to say essentially 'sodium-free'.

4.5 Interaction with other medicinal products and other forms of interaction

In an interaction study, denosumab did not affect the pharmacokinetics of midazolam, which is metabolised by cytochrome P450 3A4 (CYP3A4). This indicates that denosumab should not alter the pharmacokinetics of medicinal products metabolised by CYP3A4.

There are no clinical data on the co-administration of denosumab and hormone replacement therapy (oestrogen), however the potential for a pharmacodynamic interaction is considered to be low.

In postmenopausal women with osteoporosis the pharmacokinetics and pharmacodynamics of denosumab were not altered by previous alendronate therapy, based on data from a transition study (alendronate to denosumab).

4.6 Fertility, pregnancy and lactation

Pregnancy

There are no or limited amount of data from the use of denosumab in pregnant women. Studies in animals have shown reproductive toxicity (see section 5.3).

Resyniv[®] is not recommended for use in pregnant women and women of child-bearing potential not using contraception. Women should be advised not to become pregnant during and for at least 5 months after treatment with denosumab. Any effects of denosumab are likely to be greater during the second and third trimesters of pregnancy since monoclonal antibodies are transported across the placenta in a linear fashion as pregnancy progresses, with the largest amount transferred during the third trimester.

Breast-feeding

It is unknown whether denosumab is excreted in human milk.

In genetically engineered mice in which RANKL has been turned off by gene removal (a “knockout mouse”), studies suggest absence of RANKL (the target of denosumab see section 5.1) during pregnancy may interfere with maturation of the mammary gland leading to impaired lactation post-partum (see section 5.3). A decision on whether to abstain from breast-feeding or to abstain from therapy with biosimilar should be made, taking into account the benefit of breast-feeding to the newborn/infant and the benefit of denosumab therapy to the woman.

Fertility

No data are available on the effect of denosumab on human fertility. Animal studies do not indicate direct or indirect harmful effects with respect to fertility (see section 5.3).

4.7 Effects on ability to drive and use machines

Resyniv[®] has no or negligible influence on the ability to drive and use machines.

4.8 Undesirable effects

Summary of the safety profile

The most common side effects with denosumab (seen in more than one patient in ten) are musculoskeletal pain and pain in the extremity. Uncommon cases of cellulitis, rare cases of hypocalcaemia, hypersensitivity, osteonecrosis of the jaw and atypical femoral fractures (see sections 4.4 and 4.8 - description of selected adverse reactions) have been observed in patients taking denosumab.

Tabulated list of adverse reactions

The data in table 1 below describe adverse reactions reported from phase II and III clinical trials in patients with osteoporosis and breast or prostate cancer patients receiving hormone ablation; and/or spontaneous reporting.

The following convention has been used for the classification of the adverse reactions (see table 1): very common ($\geq 1/10$), common ($\geq 1/100$ to $< 1/10$), uncommon ($\geq 1/1,000$ to $< 1/100$), rare ($\geq 1/10,000$ to $< 1/1,000$), very rare ($< 1/10,000$) and not known (cannot be estimated from the available data). Within each frequency grouping and system organ class, adverse reactions are presented in

order of decreasing seriousness.

Table 1. Adverse reactions reported in patients with osteoporosis and breast or prostate cancer patients receiving hormone ablation.

MedDRA system organ class	Frequency category	Adverse reactions
Infections and infestations	Common Common Uncommon Uncommon Uncommon	Urinary tract infection Upper respiratory tract infection Diverticulitis ¹ Cellulitis ¹ Ear infection
Immune system disorders	Rare Rare	Drug hypersensitivity ¹ Anaphylactic reaction ¹
Metabolism and nutrition disorders	Rare	Hypocalcaemia ¹
Nervous system disorders	Common	Sciatica
Gastrointestinal disorders	Common Common	Constipation Abdominal discomfort
Skin and subcutaneous tissue disorders	Common Common Common Uncommon Very rare Not known	Rash Eczema Alopecia Lichenoid drug eruptions ¹ Hypersensitivity vasculitis Drug reaction with eosinophilia and systemic symptoms (DRESS) syndrome
Musculoskeletal and connective tissue disorder	Very common Very common Unknown Rare Rare Not known	Pain in extremity Musculoskeletal pain ¹ Multiple vertebral fractures ^{1,2} Osteonecrosis of the jaw ¹ Atypical femoral fractures ¹ Osteonecrosis of the external auditory canal ³

¹ See section Description of selected adverse reactions

² Adverse reaction observed following discontinuation of treatment with Denosumab

³ See section 4.4.

In a pooled analysis of data from all phase II and phase III placebo-controlled studies, influenza-like illness was reported with a crude incidence rate of 1.2% for denosumab and 0.7% for placebo. Although this imbalance was identified via a pooled analysis, it was not identified via a stratified analysis.

Description of selected adverse reactions

Hypocalcaemia

In two phase III placebo-controlled clinical trials in postmenopausal women with osteoporosis, approximately 0.05% (2 out of 4,050) of patients had declines of serum calcium levels (less than 1.88 mmol/L) following denosumab administration. Declines of serum calcium levels (less than 1.88

mmol/L) were not reported in either the two phase III placebo-controlled clinical trials in patients receiving hormone ablation or the phase III placebo-controlled clinical trial in men with osteoporosis.

In the post-marketing setting, rare cases of severe symptomatic hypocalcaemia resulting in hospitalisation, life-threatening events, and fatal cases have been reported predominantly in patients at increased risk of hypocalcaemia receiving Denosumab, with most cases occurring in the first weeks of initiating therapy. Examples of the clinical manifestations of severe symptomatic hypocalcaemia have included QT interval prolongation, tetany, seizures and altered mental status (see section 4.4). Symptoms of hypocalcaemia in denosumab clinical studies included paraesthesias or muscle stiffness, twitching, spasms and muscle cramps.

Skin infections

In phase III placebo-controlled clinical trials, the overall incidence of skin infections was similar in the placebo and the denosumab groups: in postmenopausal women with osteoporosis (placebo [1.2%, 50 out of 4,041] versus denosumab [1.5%, 59 out of 4,050]); in men with osteoporosis (placebo [0.8%, 1 out of 120] versus denosumab [0%, 0 out of 120]); in breast or prostate cancer patients receiving hormone ablation (placebo [1.7%, 14 out of 845] versus denosumab [1.4%, 12 out of 860]). Skin infections leading to hospitalisation were reported in 0.1% (3 out of 4,041) of postmenopausal women with osteoporosis receiving placebo versus 0.4% (16 out of 4,050) of women receiving denosumab. These cases were predominantly cellulitis. Skin infections reported as serious adverse reactions were similar in the placebo (0.6%, 5 out of 845) and the denosumab (0.6%, 5 out of 860) groups in the breast and prostate cancer studies.

Osteonecrosis of the jaw

ONJ has been reported rarely, in 16 patients, in clinical trials in osteoporosis and in breast or prostate cancer patients receiving hormone ablation including a total of 23,148 patients (see section 4.4). Thirteen of these ONJ cases occurred in postmenopausal women with osteoporosis during the phase III clinical trial extension following treatment with denosumab for up to 10 years. Incidence of ONJ was 0.04% at 3 years, 0.06% at 5 years and 0.44% at 10 years of denosumab treatment. The risk of ONJ increased with duration of exposure to denosumab.

Atypical fractures of the femur

In the osteoporosis clinical trial program, atypical femoral fractures were reported rarely in patients treated with denosumab (see section 4.4).

Diverticulitis

In a single-phase III placebo-controlled clinical trial in patients with prostate cancer receiving androgen deprivation therapy (ADT), an imbalance in diverticulitis adverse events was observed (1.2% denosumab, 0% placebo). The incidence of diverticulitis was comparable between treatment groups in postmenopausal women or men with osteoporosis and in women undergoing aromatase inhibitor therapy for non-metastatic breast cancer.

Drug-related hypersensitivity reactions

In the post-marketing setting, rare events of drug-related hypersensitivity, including rash, urticaria, facial swelling, erythema, and anaphylactic reactions have been reported in patients receiving denosumab.

Musculoskeletal pain

Musculoskeletal pain, including severe cases, has been reported in patients receiving denosumab in the post-marketing setting. In clinical trials, musculoskeletal pain was very common in both denosumab and placebo groups. Musculoskeletal pain leading to discontinuation of study treatment was uncommon.

Multiple Vertebral Fractures following discontinuation of denosumab treatment

In the osteoporosis clinical trial program, MVF were reported uncommonly in patients following

discontinuation of treatment with denosumab, particularly in those with a history of vertebral fracture.

Lichenoid drug eruptions

Lichenoid drug eruptions (e.g. lichen planus-like reactions) have been reported in patients in the post-marketing setting.

Other special populations

Paediatric population

Denosumab should not be used in paediatric patients (age < 18). Serious hypercalcaemia has been reported. Some clinical trial cases were complicated by acute renal injury.

Renal impairment

In clinical studies, patients with severe renal impairment (creatinine clearance < 30 mL/min) or receiving dialysis were at greater risk of developing hypocalcaemia in the absence of calcium supplementation. Adequate intake of calcium and vitamin D is important in patients with severe renal impairment or receiving dialysis (see section 4.4).

Reporting of suspected adverse reactions

Reporting suspected adverse reactions after authorisation of the medicinal product is important. It allows continued monitoring of the benefit/risk balance of the medicinal product. Healthcare professionals are asked to report any suspected adverse reactions via the national reporting system.

4.9 Overdose

There is no experience with overdose in clinical studies. Denosumab has been administered in clinical studies using doses up to 180 mg every 4 weeks (cumulative doses up to 1,080 mg over 6 months), and no additional adverse reactions were observed.

5. PHARMACOLOGICAL PROPERTIES

5.1 Pharmacodynamic properties

Pharmacotherapeutic group: Drugs for treatment of bone diseases – Other drugs affecting bone structure and mineralisation, ATC code: M05BX04

Mechanism of action

Denosumab is a human monoclonal antibody (IgG2) that targets and binds with high affinity and specificity to RANKL, preventing activation of its receptor, RANK, on the surface of osteoclast precursors and osteoclasts. Prevention of the RANKL/RANK interaction inhibits osteoclast formation, function and survival, thereby decreasing bone resorption in cortical and trabecular bone.

Pharmacodynamic effects

At the end of each dosing interval, CTX reductions were partially attenuated from maximal reduction of $\geq 87\%$ to approximately $\geq 45\%$ (range 45-80%), reflecting the reversibility of denosumab's effects on bone remodeling once serum levels diminish. These effects were sustained with continued treatment. Bone turnover markers generally reached pre-treatment levels within 9 months after the last dose. Upon re-initiation, reductions in CTX by denosumab were similar to those observed in patients initiating primary denosumab treatment.

Immunogenicity

In clinical studies, neutralising antibodies have not been observed for denosumab. Using a sensitive immunoassay < 1% of patients treated with denosumab for up to 5 years tested positive for non neutralising binding antibodies with no evidence of altered pharmacokinetics, toxicity, or clinical response.

Information below refers to Prolia®

Clinical efficacy and safety in postmenopausal women with osteoporosis

Efficacy and safety of denosumab administered once every 6 months for 3 years were investigated in postmenopausal women (7,808 women aged 60-91 years, of which 23.6% had prevalent vertebral fractures) with baseline bone mineral density (BMD) T-scores at the lumbar spine or total hip between -2.5 and -4.0 and a mean absolute 10-year fracture probability of 18.60% (deciles: 7.9-32.4%) for major osteoporotic fracture and 7.22% (deciles: 1.4-14.9%) for hip fracture. Women with other diseases or on therapies that may affect bone were excluded from this study. Women received calcium (at least 1,000 mg) and vitamin D (at least 400 IU) supplementation daily.

Effect on vertebral fractures

Denosumab significantly reduced the risk of new vertebral fractures at 1, 2 and 3 years ($p < 0.0001$) (see table 2).

Table 2. The effect of denosumab on the risk of new vertebral fractures

	Proportion of women with fracture (%)		Absolute risk reduction (%) (95% CI)	Relative risk reduction (%) (95% CI)
	Placebo n = 3,906	Denosumab n = 3,902		
0-1 year	2.2	0.9	1.4 (0.8, 1.9)	61 (42, 74) **
0-2 years	5.0	1.4	3.5 (2.7, 4.3)	71 (61, 79) **
0-3 years	7.2	2.3	4.8 (3.9, 5.8)	68 (59, 74) *

* $p < 0.0001$, ** $p < 0.0001$ – exploratory analysis

Effect on hip fractures

Denosumab demonstrated a 40% relative reduction (0.5% absolute risk reduction) in the risk of hip fracture over 3 years ($p < 0.05$). The incidence of hip fracture was 1.2% in the placebo group compared to 0.7% in the denosumab group at 3 years.

In a post-hoc analysis in women > 75 years, a 62% relative risk reduction was observed with denosumab (1.4% absolute risk reduction, $p < 0.01$).

Effect on all clinical fractures

Denosumab significantly reduced fractures across all fracture types/groups (see table 3).

Table 3. The effect of denosumab on the risk of clinical fractures over 3 years

	Proportion of women with fracture (%) ⁺		Absolute risk reduction (%) (95% CI)	Relative risk reduction (%) (95% CI)
	Placebo n = 3,906	Denosumab n = 3,902		
Any clinical fracture ¹	10.2	7.2	2.9 (1.6, 4.2)	30 (19, 41) ***
Clinical vertebral fracture	2.6	0.8	1.8 (1.2, 2.4)	69 (53, 80) ***
Non-vertebral fracture ²	8.0	6.5	1.5 (0.3, 2.7)	20 (5, 33) **
Major non-vertebral fracture ³	6.4	5.2	1.2 (0.1, 2.2)	20 (3, 34) *
Major osteoporotic fracture ⁴	8.0	5.3	2.7 (1.6, 3.9)	35 (22, 45) ***

* $p \leq 0.05$, ** $p = 0.0106$ (secondary endpoint included in multiplicity adjustment), *** $p \leq 0.0001$

⁺ Event rates based on Kaplan-Meier estimates at 3 years.

¹ Includes clinical vertebral fractures and non-vertebral fractures.

² Excludes those of the vertebrae, skull, facial, mandible, metacarpus, and finger and toe phalanges.

³ Includes pelvis, distal femur, proximal tibia, ribs, proximal humerus, forearm, and hip.

⁴ Includes clinical vertebral, hip, forearm, and humerus fractures, as defined by the WHO.

In women with baseline femoral neck BMD ≤ -2.5 , Denosumab reduced the risk of non-vertebral fracture (35% relative risk reduction, 4.1% absolute risk reduction, $p < 0.001$, exploratory analysis).

The reduction in the incidence of new vertebral fractures, hip fractures and non-vertebral fractures by denosumab over 3 years were consistent regardless of the 10-year baseline fracture risk.

Effect on bone mineral density

Denosumab significantly increased BMD at all clinical sites measured, versus placebo at 1, 2 and 3 years. Denosumab increased BMD by 9.2% at the lumbar spine, 6.0% at the total hip, 4.8% at the femoral neck, 7.9% at the hip trochanter, 3.5% at the distal 1/3 radius and 4.1% at the total body over 3 years (all $p < 0.0001$).

In clinical studies examining the effects of discontinuation of denosumab, BMD returned to approximately pre-treatment levels and remained above placebo within 18 months of the last dose. These data indicate that continued treatment with denosumab is required to maintain the effect of the medicinal product. Re-initiation of denosumab resulted in gains in BMD similar to those when denosumab was first administered.

Open-label extension study in the treatment of postmenopausal osteoporosis

A total of 4,550 women (2,343 denosumab & 2,207 placebo) who missed no more than one dose of investigational product in the pivotal study described above and completed the month 36 study visit agreed to enrol in a 7-year, multinational, multicentre, open-label, single-arm extension study to evaluate the long-term safety and efficacy of denosumab. All women in the extension study were to receive denosumab 60 mg every 6 months, as well as daily calcium (at least 1 g) and vitamin D (at least 400 IU). A total of 2,626 subjects (58% of the women included in the extension study i.e. 34% of the women included in the pivotal study) completed the extension study.

In patients treated with denosumab for up to 10 years, BMD increased from the pivotal study baseline by 21.7% at the lumbar spine, 9.2% at the total hip, 9.0% at the femoral neck, 13.0% at the trochanter and 2.8% at the distal 1/3 radius. The mean lumbar spine BMD T-score at the end of the study was -1.3 in patients treated for 10 years.

Fracture incidence was evaluated as a safety endpoint but efficacy in fracture prevention cannot be estimated due to high number of discontinuations and open-label design. The cumulative incidence of new vertebral and non-vertebral fractures was approximately 6.8% and 13.1% respectively, in patients who remained on denosumab treatment for 10 years ($n = 1,278$). Patients who did not complete the study for any reason had higher on-treatment fracture rates.

Thirteen adjudicated cases of osteonecrosis of the jaw (ONJ) and two adjudicated cases of atypical fractures of the femur occurred during the extension study.

Clinical efficacy and safety in men with osteoporosis

Efficacy and safety of denosumab once every 6 months for 1 year were investigated in 242 men aged 31-84 years. Subjects with an eGFR < 30 mL/min/1.73 m² were excluded from the study. All men received calcium (at least 1,000 mg) and vitamin D (at least 800 IU) supplementation daily.

The primary efficacy variable was percent change in lumbar spine BMD, fracture efficacy was not evaluated. Denosumab significantly increased BMD at all clinical sites measured, relative to placebo at 12 months: 4.8% at lumbar spine, 2.0% at total hip, 2.2% at femoral neck, 2.3% at hip trochanter, and 0.9% at distal 1/3 radius (all $p < 0.05$). Denosumab increased lumbar spine BMD from baseline in 94.7% of men at 1 year. Significant increases in BMD at lumbar spine, total hip, femoral neck and hip trochanter were observed by 6 months ($p < 0.0001$).

Bone histology in postmenopausal women and men with osteoporosis

Bone histology was evaluated in 62 postmenopausal women with osteoporosis or with low bone mass who were either naïve to osteoporosis therapies or had transitioned from previous alendronate therapy following 1-3 years treatment with denosumab. Fifty-nine women participated in the bone biopsy sub-study at month 24 (n = 41) and/or month 84 (n = 22) of the extension study in postmenopausal women with osteoporosis. Bone histology was also evaluated in 17 men with osteoporosis following 1 year treatment with denosumab. Bone biopsy results showed bone of normal architecture and quality with no evidence of mineralisation defects, woven bone or marrow fibrosis. Histomorphometry findings in the extension study in postmenopausal women with osteoporosis showed that the antiresorptive effects of denosumab, as measured by activation frequency and bone formation rates, were maintained over time.

Clinical efficacy and safety in patients with bone loss associated with androgen deprivation

Efficacy and safety of denosumab once every 6 months for 3 years were investigated in men with histologically confirmed non-metastatic prostate cancer receiving ADT (1,468 men aged 48-97 years) who were at increased risk of fracture (defined as > 70 years, or < 70 years with a BMD T-score at the lumbar spine, total hip, or femoral neck < -1.0 or a history of an osteoporotic fracture.) All men received calcium (at least 1,000 mg) and vitamin D (at least 400 IU) supplementation daily.

Denosumab significantly increased BMD at all clinical sites measured, relative to treatment with placebo at 3 years: 7.9% at the lumbar spine, 5.7% at the total hip, 4.9% at the femoral neck, 6.9% at the hip trochanter, 6.9% at the distal 1/3 radius and 4.7% at the total body (all p < 0.0001). In a prospectively planned exploratory analysis, significant increases in BMD were observed at the lumbar spine, total hip, femoral neck and the hip trochanter 1 month after the initial dose.

Denosumab demonstrated a significant relative risk reduction of new vertebral fractures: 85% (1.6% absolute risk reduction) at 1 year, 69% (2.2% absolute risk reduction) at 2 years and 62% (2.4% absolute risk reduction) at 3 years (all p < 0.01).

Clinical efficacy and safety in patients with bone loss associated with adjuvant aromatase inhibitor therapy

Efficacy and safety of denosumab once every 6 months for 2 years were investigated in women with non-metastatic breast cancer (252 women aged 35-84 years) and baseline BMD T-scores between -1.0 to -2.5 at the lumbar spine, total hip or femoral neck. All women received calcium (at least 1,000 mg) and vitamin D (at least 400 IU) supplementation daily.

The primary efficacy variable was percent change in lumbar spine BMD, fracture efficacy was not evaluated. Denosumab significantly increased BMD at all clinical sites measured, relative to treatment with placebo at 2 years: 7.6% at lumbar spine, 4.7% at total hip, 3.6% at femoral neck, 5.9% at hip trochanter, 6.1% at distal 1/3 radius and 4.2% at total body (all p < 0.0001).

Treatment of bone loss associated with systemic glucocorticoid therapy

Efficacy and safety of denosumab were investigated in 795 patients (70% women and 30% men) aged 20 to 94 years treated with ≥ 7.5 mg daily oral prednisone (or equivalent).

Two subpopulations were studied: glucocorticoid-continuing (≥ 7.5 mg daily prednisone or its equivalent for ≥ 3 months prior to study enrolment; n = 505) and glucocorticoid-initiating (≥ 7.5 mg daily prednisone or its equivalent for < 3 months prior to study enrolment; n = 290). Patients were randomised (1:1) to receive either denosumab 60 mg subcutaneously once every 6 months or oral risedronate 5 mg once daily (active control) for 2 years. Patients received calcium (at least 1,000 mg) and vitamin D (at least 800 IU) supplementation daily.

Effect on Bone Mineral Density (BMD)

In the glucocorticoid-continuing subpopulation, denosumab demonstrated a greater increase in lumbar spine BMD compared to risedronate at 1 year (Denosumab 3.6%, risedronate 2.0%; p < 0.001) and 2 years (Denosumab 4.5%, risedronate 2.2%; p < 0.001). In the glucocorticoid-initiating subpopulation,

denosumab demonstrated a greater increase in lumbar spine BMD compared to risedronate at 1 year (Denosumab 3.1%, risedronate 0.8%; $p < 0.001$) and 2 years (Denosumab 4.6%, risedronate 1.5%; $p < 0.001$).

In addition, denosumab demonstrated a significantly greater mean percent increase in BMD from baseline compared to risedronate at the total hip, femoral neck, and hip trochanter.

The study was not powered to show a difference in fractures. At 1 year, the subject incidence of new radiological vertebral fracture was 2.7% (denosumab) versus 3.2% (risedronate). The subject incidence of non-vertebral fracture was 4.3% (denosumab) versus 2.5% (risedronate). At 2 years, the corresponding numbers were 4.1% versus 5.8% for new radiological vertebral fractures and 5.3% versus 3.8% for non-vertebral fractures. Most of the fractures occurred in the GC-C subpopulation.

Paediatric population

A single-arm phase 3 study evaluated the efficacy, safety, and pharmacokinetics was conducted in children with osteogenesis imperfecta, aged 2 to 17 years, 52.3% male, 88.2% Caucasian. A total of 153 subjects initially received subcutaneous (SC) denosumab 1 mg/kg, up to a maximum of 60 mg, every 6 months for 36 months. Sixty subjects transitioned to every 3 months dosing.

At month 12 of every 3 months dosing, the least squares (LS) mean (standard error, SE) change from baseline in lumbar spine BMD Z-score was 1.01 (0.12).

The most common adverse events reported during every 6 months dosing were arthralgia (45.8%), pain in extremity (37.9%), back pain (32.7%), and hypercalciuria (32.0%). Hypercalcaemia was reported during every 6 months (19%) and every 3 months (36.7%) dosing. Serious adverse events of hypercalcaemia (13.3%) were reported during every 3 months dosing.

In an extension study (N = 75), serious adverse events of hypercalcaemia (18.5%) were observed during every 3 months dosing.

The studies were terminated early due to the occurrence of life-threatening events and hospitalisations due to hypercalcaemia (see section 4.2).

Information below refers to biosimilar Resyniv[®]

Comparative of Resyniv[®] to Prolia[®]

Based on the demonstrated analytical similarity to both reference products and the identical mechanism of action of denosumab, the comparative clinical data (Phase 1 pharmacokinetic/pharmacodynamic (PK/PD)) obtained with Dnoclast[®]-Xgeva[®], are considered applicable to Resyniv[®]-Prolia[®], thereby supporting extrapolation to all approved indications of denosumab.

Comparative pharmacokinetic, pharmacodynamic, safety and immunogenicity study MB09-A-01-19

A phase I randomized, double-blind, single-dose, three-arm parallel study was conducted in 257 healthy male volunteers to compare the pharmacokinetic (PK), pharmacodynamics (PD), Safety, and Immunogenicity of the Dnoclast[®] to EU- and US-Xgeva[®].

Following a single subcutaneous dose of 35 mg, systemic exposure (Primary End Points: AUC_{0-last} , and C_{max}) was comparable across all treatment groups. The 90% confidence intervals for the geometric least square mean ratios were within the predefined bioequivalence range of 80.00% to 125.00%, confirming PK equivalence.

Table 4: Statistical comparison of PK parameters for Dnoclast® (MB09) and Xgeva® PK populations in study MB09-A-01-19

PK Parameter (unit)	Treatment	Comparison	%Ratio GLSM	90% CI of the Ratio GLSM
AUC _{0-last} (day*ng/mL)	MB09	MB09 / EU-Xgeva	105.93	(99.54, 112.73)
	EU-Xgeva	MB09 / US-Xgeva	108.87	(102.30, 115.86)
	US-Xgeva	EU-Xgeva / US-Xgeva	102.77	(96.58, 109.37)
C _{max} (ng/mL)	MB09	MB09 / EU-Xgeva	105.13	(98.86, 111.80)
	EU-Xgeva	MB09 / US-Xgeva	104.75	(98.50, 111.40)
	US-Xgeva	EU-Xgeva / US-Xgeva	99.64	(93.69, 105.96)

Abbreviations: AUC_{0-last}, area under concentration-time curve from time 0 to the last quantifiable concentration; CI, confidence interval; C_{max}, maximum observed serum concentration; LS, least squares; n, number of subjects with evaluable values; %Ratio GLSM, percentage ratio of geometric least square means.

Percent of change from baseline serum C-terminal telopeptide of type I collagen (sCTX) levels (AUC₀₋₂₅₃) was comparable for all 3 treatment groups, hence PD equivalence was concluded based on change from baseline sCTX data with just a 2% to 4% difference in geometric LS mean were observed. Furthermore, for the 3 pairwise comparisons, the 90% CIs around the geometric LS mean ratios lay within the predefined acceptance limits (80.00%, 125.00%).

Table 5: Statistical analysis of sCTX PD parameters (AUC₀₋₂₅₃; PD population)

PD Parameter (unit)	Treatment	Comparison	%Ratio GLSM	90% CI of the %Ratio GLSM
AUC ₀₋₂₅₃ (day*%)	MB09	MB09 / EU Xgeva	103.68	(99.30, 108.24)
	EU-Xgeva	MB09 / US Xgeva	101.69	(97.42, 106.15)
	US-Xgeva	EU Xgeva / US Xgeva	98.08	(93.95, 102.41)

Abbreviations: AUC₀₋₂₅₃, area under the % inhibition curve from time 0 to Day 253 (using %CfB data); CfB, change from baseline; CI, confidence interval; n, number of subjects with evaluable values; %Ratio GLSM, ratio of geometric least square means; sCTX, serum C-terminal telopeptide of Type 1 collagen; LS, least squares.

The treatments were considered safe and generally well tolerated by healthy male, with 92 treatment-emergent adverse events (TEAE) reported during the study (majority Grade 2 and 3 in severity). All reported TEAEs resolved by the end of the study. Immunogenicity was low and similarly distributed. None of the anti-drug body (ADA) detected had neutralizing capacity. These PK and PD results supported the biosimilarity between Dnoclast®(MB09) and Xgeva®.

Comparative Safety and Efficacy

MB09-C-01-19 (Postmenopausal Women with Osteoporosis)

A Phase III, randomised, double-blind, parallel, multicentre, multinational study that was conducted in 558 subjects to compare the efficacy, PK, PD, safety and immunogenicity of Resyniv® with EU-Prolia® in postmenopausal women with osteoporosis.

The primary objective of the study was to demonstrate equivalent efficacy of Resyniv® to EU-Prolia® in postmenopausal women with osteoporosis in terms of difference in means in percentage change from baseline (%CfB) in lumbar spine bone mineral density (BMD) at Month 12. At Month 12, the difference in LS means (95% CI) in %CfB in lumbar spine BMD between Resyniv® and EU-Prolia® was 0.20 (- 0.51, 0.91). Since the 95% CI was entirely contained within the predefined margin of [-1.45, 1.45], Resyniv® is considered therapeutically equivalent to EU-Prolia® in improving lumbar spine BMD at Month 12, confirming its efficacy as a biosimilar for treating osteoporosis in postmenopausal women.

Table 6: Difference in means in %CfB in lumbar spine BMD at Month 12 (Modified full analysis set)

	Resyniv [®] (N=258)	Prolia [®] (N=266)
n	233	250
LS mean %CfB ¹	5.47	5.27
LS mean %CfB ²	5.86	5.66
LS mean difference (MB09 – Prolia [®]) ³	0.20	-
95% CI ⁴	-0.51, 0.91	-

Abbreviations: BMD, bone mineral density; BMI, body mass index; %CfB, percentage change from baseline; CI, confidence interval; LS, least square; SC, subcutaneous.

Note: The MMRM model included terms for visit by treatment; baseline BMD (g/cm²) at the lumbar spine (as a covariate); and classification variables for age, BMI, and prior use of bisphosphonates. Subject was included as a random effect.

- ¹ Using equal weights for the strata.
- ² Using weights for the strata as per representation in data (using SAS OM option).
- ³ Difference in means (MB09 – Prolia[®]) in composite endpoint of %CfB in lumbar spine BMD after 12 months (where %CfB of zero was taken for anyone who died) in postmenopausal women with osteoporosis treated with subcutaneous denosumab injections every 6 months assuming that all women received 2 denosumab doses without any errors or deviations in dosing and without the receipt of any prohibited therapies or other osteoporosis medications.
- ⁴ Therapeutic equivalence was demonstrated if 95% CI at Month 12 was entirely within the predefined margins of [-1.45%, 1.45%].

Table 7: Statistical analysis of sCTX PD parameters in study MB09-C-01-19 (Main Treatment Period; Modified full analysis set)

Absolute scale			Ratio of Geometric Means Resyniv [®] (MB09)/Prolia [®] (%)		
PD Parameter (units)	Treatment	Geometric LS Means (n)	Estimate ¹	90% CI	95% CI
AUEC _{0-6 months} (day*pg/mL)	MB09	11,700 (218)	99.91	(93.22, 107.08)	(91.99, 108.52)
	Prolia [®]	11,700 (228)			
AUEC _{0-181 days} (day*pg/mL)	MB09	11,600 (240)	99.37	(92.98, 106.20)	(91.79, 107.56)
	Prolia [®]	11,700 (242)			
AUIC _{0-6 months} (day*%)	MB09	14,900 (218)	99.13	(96.76, 101.55)	(96.31, 102.02)
	Prolia [®]	15,100 (228)			
AUIC _{0-181 days} (day*%)	MB09	14,900 (240)	99.81	(97.51, 102.16)	(97.07, 102.62)
	Prolia [®]	15,000 (242)			

Abbreviations: AUEC_{0-6 months}, area under the effect curve for absolute sCTX concentrations from zero to 6 months; AUIC_{0-6 months}, area under the inhibition curve for percentage change from baseline sCTX concentrations from zero to 6 months; CI, confidence interval, LS, least squares; n, number of evaluable values; PD, pharmacodynamic; sCTX, serum carboxy terminal cross linking telopeptide of type I collagen

Following a SC dose of MB09, absolute sCTX levels (AUEC_{0-6 months}) were comparable for both treatment groups. Furthermore, the 95% CIs around the geometric LS mean ratios lay within the predefined acceptance limits (80.00%, 125.00%). The geometric LS mean ratio (95% CI) [Resyniv[®](MB09)/Prolia[®]] for AUEC_{0-6 months} was 99.91% (91.99%, 108.52%).

Following a SC dose of MB09, %CfB in sCTX levels (AUIC_{0-6 months}) were comparable for both treatment groups. Furthermore, the 95% CIs around the geometric LS mean ratios lay within the predefined acceptance limits (80.00%, 125.00%). The geometric LS mean ratio (95% CI) [Resyniv[®](MB09)/Prolia[®]] for AUIC_{0-6 months} was 99.13% (96.31%, 102.02%).

Safety

Resyniv[®] demonstrated a safety profile similar to that of the EU-Prolia[®] in terms of nature, severity, and frequency of the Treatment-Emergent Adverse Event (TEAEs). Furthermore, the safety profile of Resyniv[®] (MB09) was within the expectations in the study population.

Immunogenicity

Resyniv[®] demonstrated a low immunogenicity profile, consistent with expectations based on EU-Prolia[®]'s known characteristics. No evidence of neutralizing antibodies or impact on clinical outcomes. These findings supported Resyniv[®]'s biosimilarity and safety in terms of immunogenic response.

The safety profile, as well as the PK and PD profiles, remained similar after single transition from Prolia[®] to MB09 as compared with MB09 throughout or Prolia[®] throughout.

Overall, the results from data collected from all subjects who completed the 12-month Main Treatment Period of the study demonstrated that Resyniv[®] was well tolerated with acceptable safety profile and an improvement in BMD that was comparable to EU-Prolia[®]. Overall, the comparable PK and PD profiles of Resyniv[®] and EU-Prolia[®] supported the clinical efficacy of Resyniv[®] in postmenopausal women with osteoporosis.

5.2 Pharmacokinetic properties

Absorption

Following subcutaneous administration of a 1.0 mg/kg dose, which approximates the approved 60 mg dose, exposure based on AUC was 78% as compared to intravenous administration at the same dose level. For a 60 mg subcutaneous dose, maximum serum denosumab concentrations (C_{max}) of 6 mcg/mL (range 1-17 mcg/mL) occurred in 10 days (range 2-28 days).

Biotransformation

Denosumab is composed solely of amino acids and carbohydrates as native immunoglobulin and is unlikely to be eliminated via hepatic metabolic mechanisms. Its metabolism and elimination are expected to follow the immunoglobulin clearance pathways, resulting in degradation to small peptides and individual amino acids.

Elimination

After C_{max} , serum levels declined with a half-life of 26 days (range 6-52 days) over a period of 3 months (range 1.5-4.5 months). Fifty-three percent (53%) of patients had no measurable amounts of denosumab detected at 6 months post-dose.

No accumulation or change in denosumab pharmacokinetics with time was observed upon subcutaneous multiple-dosing of 60 mg once every 6 months. Denosumab pharmacokinetics were not affected by the formation of binding antibodies to denosumab and were similar in men and women. Age (28-87 years), race and disease state (low bone mass or osteoporosis; prostate or breast cancer) do not appear to significantly affect the pharmacokinetics of denosumab.

A trend was observed between higher body weight and lower exposure based on AUC and C_{max} . However, the trend is not considered clinically important, since pharmacodynamic effects based on bone turnover markers and BMD increases were consistent across a wide range of body weight.

Linearity/non-linearity

In dose ranging studies, denosumab exhibited non-linear, dose-dependent pharmacokinetics, with lower clearance at higher doses or concentrations, but approximately dose-proportional increases in exposures for doses of 60 mg and greater.

Renal impairment

In a study of 55 patients with varying degrees of renal function, including patients on dialysis, the degree of renal impairment had no effect on the pharmacokinetics of denosumab.

Hepatic impairment

No specific study in patients with hepatic impairment was performed. In general, monoclonal antibodies are not eliminated via hepatic metabolic mechanisms. The pharmacokinetics of denosumab is not expected to be affected by hepatic impairment.

Paediatric population

Resyniv[®] should not be used in paediatric populations (see sections 4.2 and 5.1).

In a phase 3 study of paediatric patients with osteogenesis imperfecta (N = 153), maximum serum denosumab concentrations were observed on day 10 across all age groups. For every 3 months and every 6 months dosing, mean serum denosumab trough concentrations were observed to be higher for children 11 to 17 years of age, while children 2 to 6 years of age had the lowest mean trough concentrations.

5.3 Preclinical safety data

In single and repeated dose toxicity studies in cynomolgus monkeys, denosumab doses resulting in 100 to 150 times greater systemic exposure than the recommended human dose had no impact on cardiovascular physiology, male or female fertility, or produced specific target organ toxicity.

Standard tests to investigate the genotoxicity potential of denosumab have not been evaluated, since such tests are not relevant for this molecule. However, due to its character it is unlikely that denosumab has any potential for genotoxicity.

The carcinogenic potential of denosumab has not been evaluated in long-term animal studies.

In preclinical studies conducted in knockout mice lacking RANK or RANKL, impairment of lymph node formation was observed in the foetus. An absence of lactation due to inhibition of mammary gland maturation (lobulo-alveolar gland development during pregnancy) was also observed in knockout mice lacking RANK or RANKL.

In a study of cynomolgus monkeys dosed with denosumab during the period equivalent to the first trimester at AUC exposures up to 99-fold higher than the human dose (60 mg every 6 months), there was no evidence of maternal or foetal harm. In this study, foetal lymph nodes were not examined.

In another study of cynomolgus monkeys dosed with denosumab throughout pregnancy at AUC exposures 119-fold higher than the human dose (60 mg every 6 months), there were increased stillbirths and postnatal mortality; abnormal bone growth resulting in reduced bone strength, reduced haematopoiesis, and tooth malalignment; absence of peripheral lymph nodes; and decreased neonatal growth. A no observed adverse effect level for reproductive effects was not established. Following a 6 month period after birth, bone related changes showed recovery and there was no effect on tooth eruption. However, the effects on lymph nodes and tooth malalignment persisted, and minimal to moderate mineralisation in multiple tissues was seen in one animal (relation to treatment uncertain). There was no evidence of maternal harm prior to labour; adverse maternal effects occurred infrequently during labour. Maternal mammary gland development was normal.

In preclinical bone quality studies in monkeys on long-term denosumab treatment, decreases in bone turnover were associated with improvement in bone strength and normal bone histology. Calcium levels were transiently decreased and parathyroid hormone levels transiently increased in ovariectomized monkeys treated with denosumab.

In male mice genetically engineered to express huRANKL (knock-in mice), which were subjected to a transcortical fracture, denosumab delayed the removal of cartilage and remodelling of the fracture callus compared to control, but biomechanical strength was not adversely affected.

Knockout mice (see section 4.6) lacking RANK or RANKL exhibited decreased body weight, reduced bone growth and lack of tooth eruption. In neonatal rats, inhibition of RANKL (target of denosumab therapy) with high doses of a construct of osteoprotegerin bound to Fc (OPG-Fc) was associated with inhibition of bone growth and tooth eruption. These changes were partially reversible in this model when dosing with RANKL inhibitors was discontinued. Adolescent primates dosed with denosumab at 27 and 150 times (10 and 50 mg/kg dose) the clinical exposure had abnormal growth plates. Therefore,

treatment with denosumab may impair bone growth in children with open growth plates and may inhibit eruption of dentition.

6. PHARMACEUTICAL PARTICULARS

6.1 List of excipients

Acetic acid, glacial*

Sodium hydroxide (for pH adjustment) *

Sorbitol (E420)

Polysorbate 20

Water for injections

* *Acetate buffer is formed by mixing acetic acid with sodium hydroxide*

6.2 Incompatibilities

In the absence of compatibility studies, this medicinal product must not be mixed with other medicinal products.

6.3 Shelf life

The expiry date is indicated on the packaging.

6.4 Special precautions for storage

Store in a refrigerator (2°C – 8°C).

Do not freeze.

Keep the pre-filled syringe in the outer carton in order to protect from light.

Do not shake.

Once removed from the refrigerator, Resyniv[®] may be stored at room temperature (up to 25°C) for up to 30 days in the original container. It must be used within this 30 days period.

6.5 Nature and contents of container

Resyniv[®] is a sterile and preservative-free product.

Pre-filled syringe

One mL solution in a single use pre-filled syringe made from type I glass with stainless steel 29-gauge needle, with bromobutyl plunger stopper coated with fluoropolymer film and with needle guard.

Pack size of one pre-filled syringe, presented in carton box (pre-filled syringe with a needle guard).

6.6 Special precautions for disposal and other handling

- Before administration, the solution should be inspected.
- Do not inject the solution if it contains particles or is cloudy or discoloured.
- Do not shake.
- To avoid discomfort at the site of injection, allow the pre-filled syringe to reach room temperature (up to 25°C) before injecting and inject slowly.
- Inject the entire contents of the pre-filled syringe.

Any unused medicinal product or waste material should be disposed of in accordance with local requirements.

7. PRODUCT REGISTRATION HOLDER

Abbott Laboratories(M) Sdn. Bhd.

27-02, Level 27, Imazium,

8 Jalan SS21/37, Damansara Uptown

47400 Petaling Jaya, Selangor Malaysia

8. DATE OF REVISION OF THE TEXT

Dec 2025

(Note: “Denosumab” in this package insert refers to Prolia[®], while “biosimilar” refers to Resyniv[®])

INSTRUCTION FOR USE

Read these instructions before you start using Resyniv[®] pre-filled syringes with needle guard and each time you get a new package. These may be new information. You should also talk to your healthcare professional about your medical condition or your treatment.

Keep the Instructions for Use so you can read them again if necessary.

IMPORTANT INFORMATION

Important information you need to know before injecting Resyniv[®]:

- It is important that you do not try to give yourself the injection unless you have received training on the right way to inject Resyniv[®] from your doctor or healthcare professional.
- Resyniv[®] is for subcutaneous injection only (inject directly under the skin).
- **Do not** open the outer box until you are ready to use this medicine.
- **Do not** remove the needle cap from the pre-filled syringe until you are ready to inject.
- **Do not** use the pre-filled syringe if it has been dropped on a hard surface. Use a new pre-filled syringe and call your doctor or healthcare professional.
- **Do not** attempt to activate the pre-filled syringe prior to injection.
- **Do not** attempt to remove the needle guard from the pre-filled syringe.

Call your doctor or healthcare professional if you or your caregiver have any questions about the right way to inject Resyniv[®].

Figure 1 shows what the pre-filled syringe with needle guard looks like before (a) and after (b) use.

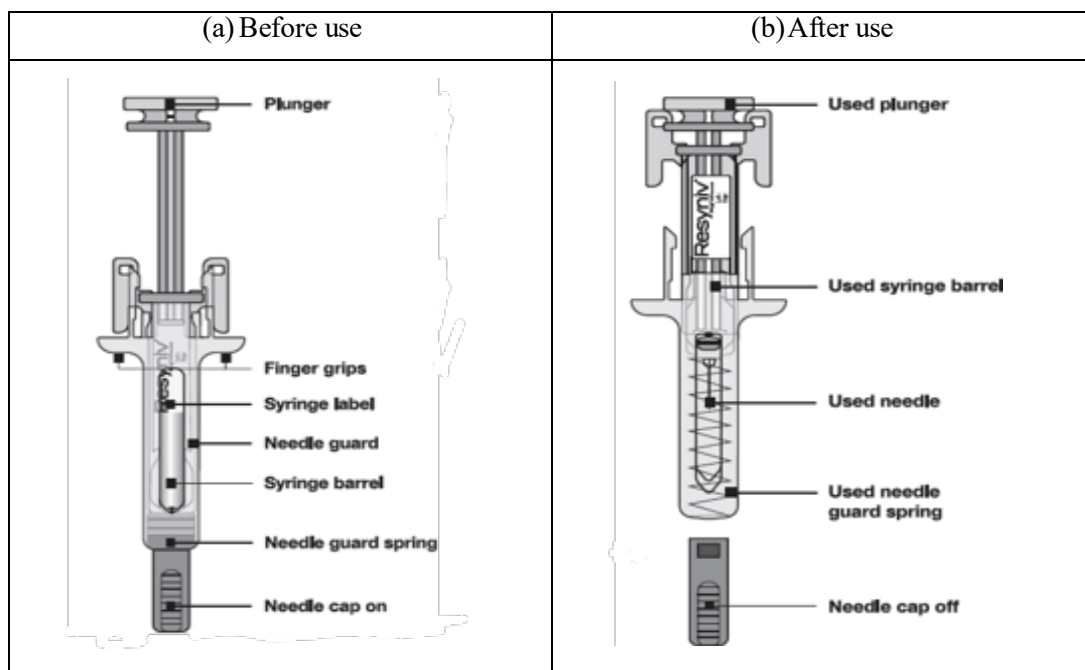

Figure 1

1. Prepare to Inject Resyniv[®]

Gather supplies

- On a clean, well-lit work surface, gather the supplies needed for your injection:
 - Resyniv[®] carton with pre-filled syringe
 - Alcohol wipes
 - Cotton ball or gauze pad
 - Plaster
 - Sharps disposal container

Acclimate to room temperature

- For a more comfortable injection, leave the carton with pre-filled syringe inside at room temperature for about 30 minutes before injecting (**Figure A**).
 - **Do not** try to warm the pre-filled syringe by using a heat source such as hot water or microwave.
 - **Do not** leave the pre-filled syringe exposed to direct sunlight.
 - **Do not** shake the pre-filled syringe.
 - **Keep the pre-filled syringe out of the sight and reach of children.**

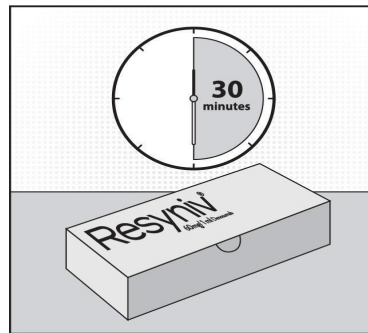

Figure A

Wash hands

- Wash your hands thoroughly with soap and water (**Figure B**).

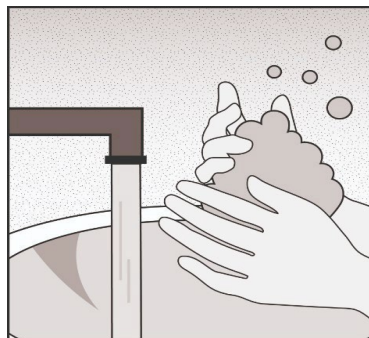

Figure B

Remove the pre-filled syringe from the carton

- Open the carton.
- Grab the pre-filled syringe by the body (**Figure C**).
- Lift the syringe straight out of the carton.
- Put the syringe on a clean and flat work surface.

For safety reasons:

- **Do not** grasp the plunger.
- **Do not** grasp the needle cap.

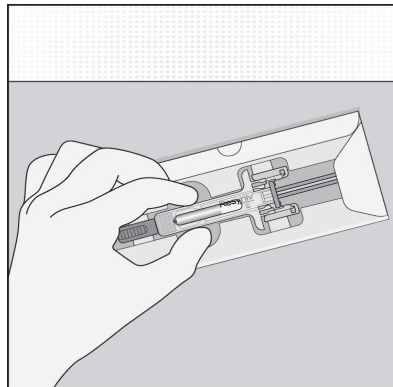

Figure C

Check medicine and pre-filled syringe

- Check the product name “Resyniv[®]” is printed on the label (**Figure D**).
- Check the expiry date printed on the label (**Figure D**).
- Check the medicine to be a clear, colorless to slightly yellow solution (**Figure D**).
- Check the pre-filled syringe for any damage.

Do not use the pre-filled syringe if:

- The medicine is cloudy or there are particles in it.
- Any part appears cracked or broken.
- The needle cap is missing or not securely attached.
- The expiry date printed on the label has passed the last day of the month shown.

In all cases included above, call your doctor or healthcare professional.

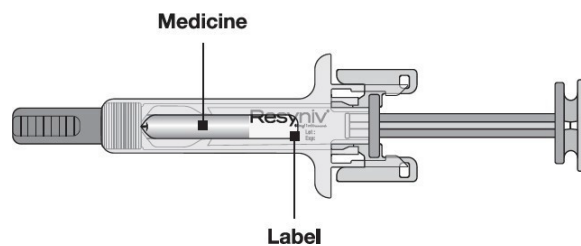

Figure D

2. Get Ready

Prepare injection site

- Select your injection site (**Figure E**):
You can use:
 - Upper part of your thigh.
 - Belly, except for a 5 cm area right around your belly button.
 - Outer area of upper arm (only if someone else is giving you the injection).
- **Do not** inject into areas where the skin is tender, bruised, red, or hard. Avoid injecting into areas with scars or stretch marks.

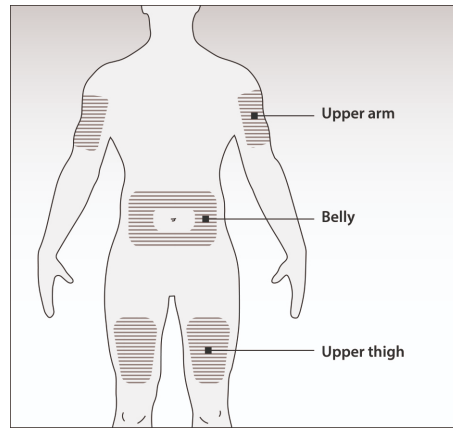

Figure E

Clean injection site

- Clean the injection site with an alcohol wipe (**Figure F**).
- Let the skin dry.
- **Do not** touch the injection site before injecting.

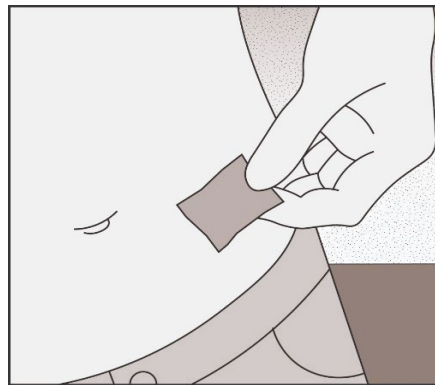

Figure F

Remove needle cap

- Carefully pull the needle cap straight off and away from your body (**Figure G**).
- Throw away the needle cap.
- **Do not** attempt to re-cap the needle.

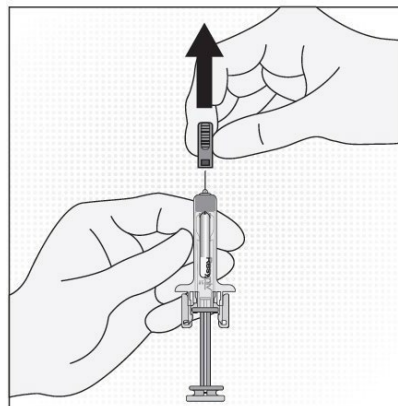

Figure G

3. Inject Resyniv[®]

Insert the needle

- Pinch your injection site to create a firm surface (**Figure H**).
- **Do not** touch the cleaned area of the skin.
Note: It is important to keep the skin pinched when injecting.
- Insert the needle at 45 to 90-degree angle into the pinched skin (**Figure I**).

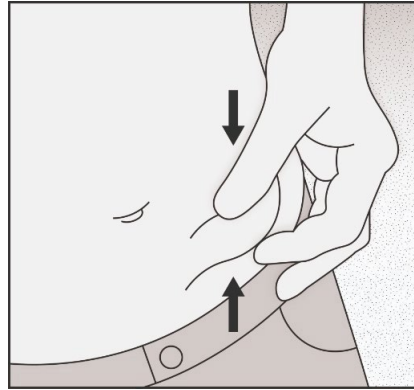

Figure H

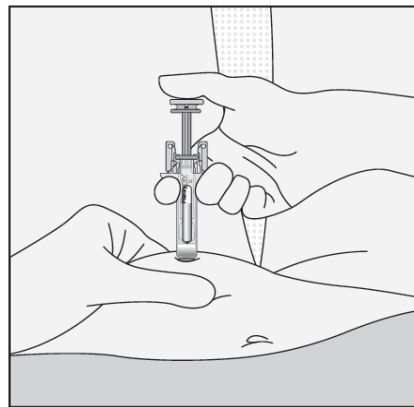

Figure I

Inject Resyniv[®]

- Slowly push the plunger all the way in until all the liquid is injected, and the syringe is empty (**Figure J**).
Note: The plunger must be pushed all the way down to be sure the full dose has been injected and the needle guard will activate.

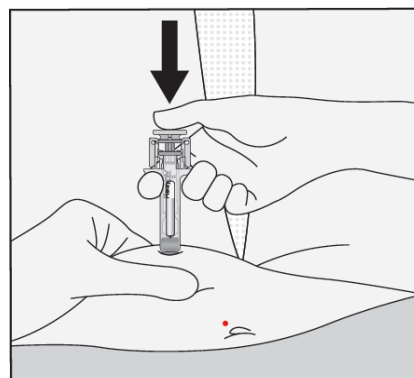

Figure J

Release your thumb

- Take your thumb off the plunger to allow the needle guard to cover the needle (**Figure K**).
- Then lift the syringe off the skin (**Figure L**).
- Release the pinched skin.

Call your doctor or healthcare professional right away if:

- You did not inject the full dose or
- The needle guard does not activate after injecting.

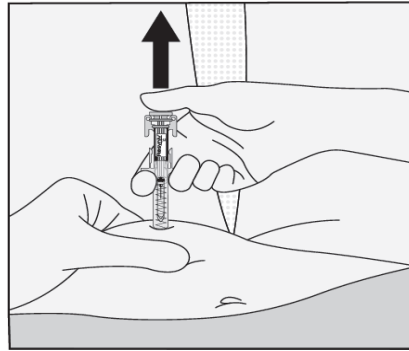

Figure K

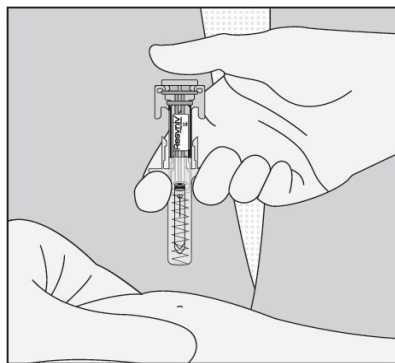

Figure L

4. Dispose of Resyniv[®]

Dispose of the syringe

- Discard the used pre-filled syringe and other supplies in a sharp's disposal container (**Figure M**).
Note: Medicines should be disposed of in accordance with local requirements. Ask your doctor or healthcare professional how to dispose of medicines no longer required. These measures will help to protect the environment.
- **Do not** put the needle cap back on used pre-filled syringes.
- **Do not** reuse the pre-filled syringe even if all the medicine was not injected.
- **Do not** recycle pre-filled syringes or throw them into household waste.
- **Keep the syringe and sharps disposal container out of the sight and reach of children.**

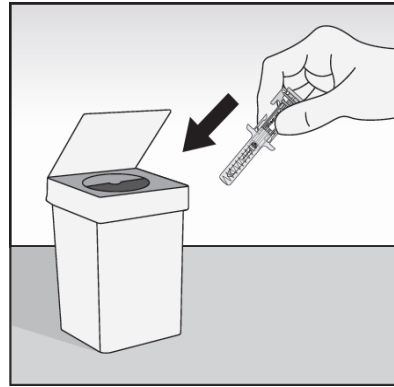

Figure M

Examine the injection site

- If there is blood, press a cotton ball or gauze pad on your injection site.
- **Do not** rub the injection site. Apply a plaster if needed.

Record date of next injection

- Record the date of your next injection on the reminder card included in the pack (**Figure N**).

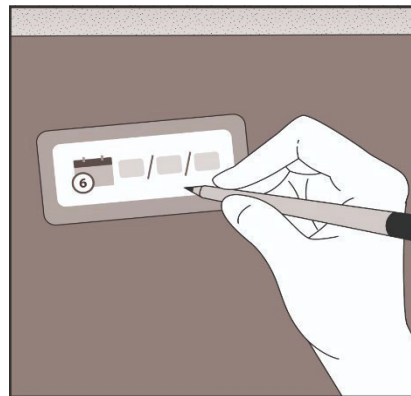

Figure N