

# XOLAIR®

Omalizumab (75mg/0.5ml, 150mg/ml and 300mg/2ml) solution for injection in pre-filled syringe

## What is in this leaflet

1. What Xolair is used for
2. How Xolair works
3. Before you use Xolair
4. How to use Xolair
5. While you are using it
6. Side effects
7. Storage and Disposal of Xolair
8. Product description
9. Manufacturer
10. Product registration holder
11. Date of revision
12. Serial number
13. Instruction for use

## What Xolair is used for

### *Allergic Asthma (adults and adolescents – 12 years of age and above)*

Xolair (omalizumab) is indicated for adults and adolescents (12 years of age and above) with moderate to severe persistent allergic asthma whose symptoms are inadequately controlled with inhaled corticosteroids (ICS).

### *Allergic Asthma (children – 6 to < 12 years of age)*

Xolair is indicated as add-on therapy to improve asthma control with severe persistent allergic asthma who have a positive skin test or in vitro reactivity to a perennial aeroallergen and frequent daytime symptoms or night-time awakenings and who have had multiple documented severe asthma exacerbations despite daily high-dose inhaled corticosteroids, plus a long-acting inhaled beta2-agonist.

Xolair has been shown to decrease the incidence of asthma exacerbations in these patients. Safety and efficacy have not been established in other allergic conditions.

### *Chronic rhinosinusitis with nasal polyps (CRSwNP)*

Xolair is used to treat CRSwNP in adults (18 years of age and older) whose disease

is not well controlled with their current CRSwNP medicines. Xolair helps reduce the size of the polyps and improves symptoms caused by CRSwNP including nasal congestion, loss of sense of smell, post-nasal drip and runny nose.

### *Chronic Spontaneous Urticaria (CSU)*

Xolair is indicated as add-on therapy for the treatment of chronic spontaneous urticaria in adult and adolescent (12 years and above) patients with inadequate response to H1 antihistamine treatment.

## How it works

### *Allergic Asthma and CRSwNP*

Xolair works by blocking a substance called immunoglobulin E (also known simply as IgE) which is produced by your body. IgE contributes to a type of inflammation that plays a key role in causing allergic asthma and CRSwNP. Your doctor will measure the amount of IgE in your blood before starting the treatment with Xolair.

### *Chronic Spontaneous Urticaria (CSU)*

Xolair works by blocking a substance called immunoglobulin E (also known simply as IgE) which is produced by your body. As a consequence, the activity of specific receptors and/or cells in your body which play a key role in causing chronic spontaneous urticaria are reduced. This leads to a reduction of your symptoms, like itching and hives.

## Before you use Xolair

### *-When you must not use it*

If you are allergic to Xolair or any of the ingredients of Xolair listed at the end of this leaflet.

If you think you may be allergic, ask your doctor for advice.

### *- Before you start to use it*

### *Warnings and precautions*

Tell your doctor before you use Xolair:

- If you have kidney or liver problems.
- If you have a disorder where your own immune system attacks parts of

your own body (autoimmune disease).

- If you live in a region where parasite infections are frequent or traveling to such a region, Xolair may weaken your resistance to such infections.
- If you have had a previous severe allergic reaction (anaphylaxis) resulting, for example, from a medicine, an insect bite or food.
- If you have ever had an allergic reaction to latex. The needle cap of the pre-filled syringe may contain dry rubber (latex).

### *Look out for signs of allergic reactions and other serious side effects*

Xolair can potentially cause serious side effects. You must look out for signs of these conditions while you use Xolair. Seek medical help immediately if you notice any signs indicating a severe allergic reaction or other serious side effects. Such signs are listed under sub-section "Some side effects can be serious" in section Side effect.

It is important that you receive training from your doctor or healthcare professional in how to recognize early signs of severe allergic reactions, and how to manage these reactions if they occur (see section How to use Xolair). The majority of severe allergic reactions occur within the first 3 doses of Xolair.

## *Children and adolescents*

### *Allergic Asthma*

Do not give Xolair to children under 6. Its use in children below 6 years of age has not been studied sufficiently.

### *CRSwNP*

Do not give Xolair to children and adolescents under 18. Its use in children and adolescents below 18 years of age has not been studied.

### *Chronic Spontaneous Urticaria*

Do not give Xolair to children under 12. Its use in children below 12 years of age has not been studied sufficiently.

### **Older people (65 years or above)**

Xolair may be given to people aged 65 years and over. There is no evidence to suggest that any special precautions are needed when older people are treated, although experience is still limited.

### **Pregnancy**

If you are pregnant or plan to become pregnant, tell your doctor before starting treatment with Xolair. Your doctor will discuss with you the benefits and potential risks of using this medicine during pregnancy.

If you become pregnant while being treated with Xolair, tell your doctor straight away.

### **Breast-feeding**

If you are breast-feeding or intend to breast-feed, get advice from your doctor before using Xolair. Xolair may be passed in your breast milk to your baby.

### **Taking other medicines**

Please tell your doctor or pharmacist if you are taking or have recently taken any other medicines, even those not prescribed.

Xolair can be used together with inhaled and/or intranasal corticosteroids and other medicines for allergic asthma and/or CRSwNP as well as with H1 or H2 antihistamines and LTRAs for chronic spontaneous urticaria, but it is still important to tell your doctor that you are taking them before you are given Xolair.

### **How to use Xolair**

Always use this medicine exactly as your doctor has told you. Check with your doctor, nurse or pharmacist if you are not sure.

#### - How much to use

#### **Allergic Asthma and CRSwNP**

Your doctor will decide how much Xolair you need and how often you will need it. This depends on your body weight and the results of a blood test carried out before the start of the treatment to measure the amount of IgE in your blood. You will need 1 to 4 injections at a time. You will need the injections either every two weeks or every four weeks as prescribed by your doctor.

Xolair 300 mg pre-filled syringe is not intended for use in children under 12

years of age. Xolair 75 mg pre-filled syringe and Xolair 150 mg pre-filled syringe may be used in children 6-11 years of age with allergic asthma. Keep taking your current asthma and/or CRSwNP medicine during Xolair treatment. Do not stop taking any asthma and/or CRSwNP medication without talking to your doctor.

#### **Chronic Spontaneous Urticaria**

You will need 1 or 2 injections at a time every four weeks.

Keep taking your current medicine for CSU during Xolair treatment. Do not stop taking any medicine without talking to your doctor.

#### - When to use it

#### **Allergic Asthma and CRSwNP**

You will need the injections either every two weeks or every four weeks as prescribed by your doctor.

#### **Chronic Spontaneous Urticaria**

You will need 1 or 2 injections at a time every four weeks.

#### - How long to use it

Continue to use Xolair for as long as your doctor tells you.

If you have questions about how long to use Xolair, talk to your doctor or your pharmacist.

#### **Allergic Asthma and CRSwNP**

You may not see an immediate improvement after beginning Xolair therapy. It usually takes several weeks to have the full effect.

#### - If you forget to use it

If you have missed an appointment to get a Xolair injection, contact your doctor and get it as soon as you remember.

If you have forgotten a dose of Xolair, inject the dose as soon as you remember. Then talk to your doctor to discuss when to inject the next dose.

#### - If you use too much (overdose)

If you accidentally use more Xolair than prescribed, please contact your doctor for further advice.

#### **While you are using it**

#### - Things you must do

#### **How Xolair is used**

Xolair is used as an injection under your skin (known as a subcutaneous injection).

### **Injecting Xolair**

- You and your doctor will decide if you should inject Xolair yourself. The first 3 doses should be given by or under the supervision of a healthcare professional (see Section 'Before you use Xolair').
- It is important to be properly trained on how to inject the medicine before injecting yourself.
- A caregiver (for example a parent) may also give you your Xolair injection after he or she has received proper training.

For detailed instructions on how to inject Xolair, see 'Instructions for use' at the end of this leaflet.

### **Training to recognize serious allergic reactions**

It is also important that you do not inject Xolair yourself until you have been trained by your doctor or nurse on:

- how to recognize the early signs and symptoms of serious allergic reactions.
  - what to do if the signs occur.
- For more information about the early signs and symptoms of serious allergic reactions, see section Side effect.

#### - Things you must not do

You should not use Xolair to prevent or treat other allergy-type conditions:

- sudden allergic reactions
- *hyperimmunoglobulin E syndrome* (an inherited immunodeficient disorder)
- *aspergillosis* (a fungus-related lung disease)
- food allergy, allergic skin rash or hay fever.

You should not use Xolair to treat acute asthma symptoms, like a sudden asthma attack. You will have been given a separate medicine for this.

#### - Things to be careful of

#### **If you stop using Xolair**

Interrupting or ending the treatment with Xolair may lead to recurrence of your symptoms.

If you have any further questions on the use of Xolair, ask your doctor, pharmacist or healthcare provider.

### **Side effects**

As with all medicines, patients treated with Xolair can experience side effects, although not everybody gets them.

**Some side effects can be serious**  
**Seek medical attention immediately if you notice any signs of the following side effects:**

**Rare:** *may affect up to 1 in every 1,000 people*

Xolair contains a protein, and as with any protein, local or systemic allergic reactions may potentially occur. Sudden severe allergic reactions have been rarely reported. If you notice sudden signs of allergy such as rash, itching or hives on the skin, swelling of the face, lips, tongue, larynx (voice box), windpipe or other parts of the body, fast heartbeat, dizziness and light headedness, shortness of breath, wheezing or trouble breathing, tell your doctor immediately.

**Not known:** *frequency cannot be estimated from the available data*

- Low blood platelet count with symptoms such as bleeding or bruising more easily than normal (signs of so-called “thrombocytopenia”).
- Joint appearance of some of the following symptoms: Pain, numbness or tingling in the arms and legs, lumps or raised patches in the skin, weakness and fatigue, loss of appetite and weight loss (signs of so-called “Churg-Strauss syndrome”).
- Joint appearance of some of the following symptoms: Joint pain, stiffness, rash, fever, swollen/enlarged lymph nodes (signs of so-called serum-sickness). When it occurs this is usually between one to five days after injection.

#### **Other possible side effects**

Other side effects include the following listed below. If these side effects become severe, please tell your doctor, pharmacist or healthcare provider.

**Very common:** *may affect more than 1 in 10 people*

- fever (in children)

**Common:** *may affect up to 1 in every 10 people*

- reactions at the injection site including pain, swelling, itching and redness

- pain in the upper part of the abdomen
- headache (very common in children)
- feeling dizzy
- sore throat and blocked nose (nasopharyngitis)
- feeling of pressure or pain in the cheeks and forehead (sinusitis and sinus headache)
- upper respiratory tract infection, such as inflammation of the pharynx and common cold
- burning sensation or pain when passing urine and having to urinate frequently (possible symptom of an urinary tract infection)
- pain in upper or lower limbs (arms and/or legs)
- pain in muscles and/or bones and/or joints (musculoskeletal pain, myalgia, arthralgia)

**Uncommon:** *may affect up to 1 in every 100 people*

- feeling sleepy or tired
- tingling or numbness of the hands or feet
- fainting, postural hypotension (low blood pressure while sitting or standing), flushing
- sore throat, coughing, acute breathing problems
- nausea, diarrhea, indigestion
- itching, hives, rash, increased sensitivity of the skin to sun
- weight increase
- flu-like symptoms
- swelling arms

**Rare:** *may affect up to 1 in every 1000 people*

- parasite infections

**Not known:** *frequency cannot be estimated from the available data*

- joint swelling
- hair loss

If you notice any other side effects not mentioned in this leaflet, please inform your doctor, pharmacist or healthcare provider.

You may report any side effects or adverse drug reactions directly to the National Centre for Adverse Drug Reaction Monitoring by visiting the website [npra.gov.my](http://npra.gov.my) [Consumers -->

Reporting Side Effects to Medicines (ConSERF) or Vaccines (AEFI)]

#### **Storage and Disposal of Xolair**

##### - Storage

- Do not use after the expiry date shown on the box
- Store at 2°C–8°C (in a refrigerator). Do not freeze. Store in the original package in order to protect from light.
- Keep out of the sight and reach of children.

##### - Disposal

Ask your pharmacist how to dispose of medicines you no longer use.

#### **Product Description**

##### - What it looks like

#### **Solution for injection in pre-filled syringe**

Xolair 75 mg comes as a clear to slightly opalescent, colorless to pale brownish-yellow solution for injection in a pre-filled syringe. Each pre-filled syringe of 0.5 mL contains 75 mg of omalizumab. Xolair 150 mg comes as a clear to slightly opalescent, colorless to pale brownish-yellow solution for injection in a pre-filled syringe. Each pre-filled syringe of 1 mL contains 150 mg of omalizumab. Xolair 300 mg comes as a clear to slightly opalescent, colorless to pale brownish-yellow solution for injection in a pre-filled syringe. Each pre-filled syringe of 2 mL contains 300 mg of omalizumab.

Xolair is available in packs with 1 pre-filled syringe of either 0.5 mL (75 mg), 1 mL (150 mg) or 2 mL (300mg) solution for injection.

This information might differ in some countries.

##### - Ingredients

- The **active substance** of Xolair is omalizumab
- The **other ingredients** are: L-arginine hydrochloride, L-histidine hydrochloride monohydrate, L-histidine, polysorbate 20, water for injection (for the needle cap of Xolair pre-filled syringe, see section ‘Before you use Xolair’ and ‘Instructions for use’ for further information on latex).

This information might differ in some countries

*- MAL number:*

Xolair 75mg/0.5ml Solution for Injection in Pre-filled Syringe:  
MALXXXXXXXXXARZ

Xolair 150mg/ml Solution for Injection in Pre-filled Syringe:  
MALXXXXXXXXXARZ

Xolair 300mg/2ml Solution for Injection in Pre-filled Syringe:  
MALXXXXXXXXXARZ

**Manufacturer**

Novartis Pharma Stein AG  
Schaffhauserstrasse  
4332 Stein  
Switzerland

**Product Registration Holder**

Novartis Corporation (Malaysia) Sdn. Bhd.  
Level 18, Imazium,

No.8, Jalan SS21/37, Damansara Uptown,  
47400 Petaling Jaya.

**Date of revision**

10 Jan 2025 (Information issued on 29 Jun 2023)

**Serial Number**

NPRA (R3)24/71

**Instructions for Use**

**Xolair solution for injection in pre-filled syringe (pre-filled syringe with 27-gauge staked needle)**

This “Instructions for Use” contains information on how to inject Xolair.

If your doctor decides that you or your caregiver may be able to give your injections of Xolair at home, ensure that your doctor or nurse shows you or your caregiver how to prepare and inject with the Xolair pre-filled syringe before you use it for the first time.

Children below 12 years of age are not expected to inject Xolair themselves, however, if deemed appropriate by their doctor, a caregiver may give them their Xolair injections after proper training.

Be sure that you read and understand this “Instructions for Use” before injecting with the Xolair pre-filled syringe. Talk to your doctor if you have any questions.

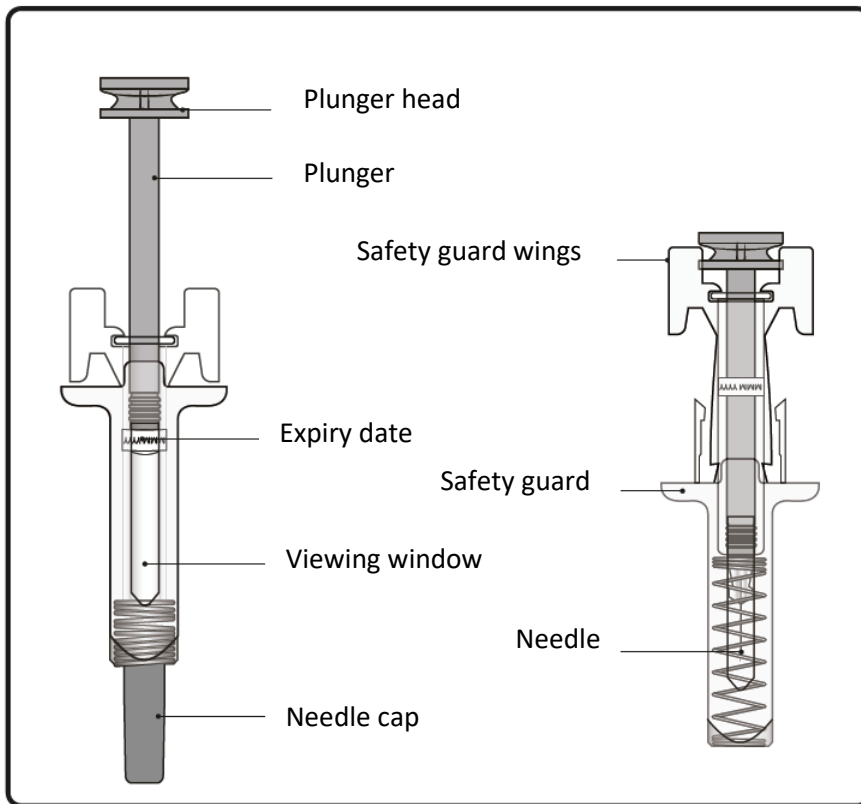

### Important information you need to know before injecting Xolair

- Xolair is for subcutaneous injection only (inject directly into fatty layer under the skin).
- **Do not** use the pre-filled syringe if either the seal on the outer carton or the seal of the plastic tray is broken.
- **Do not** use if the pre-filled syringe has been dropped onto a hard surface or dropped after removing the needle cap.
- **Do not** inject if the pre-filled syringe has been kept out of the refrigerator for more than a total of 48 hours. Dispose of it (see Step 12) and use a new pre-filled syringe for your injection.
- The pre-filled syringe has a safety guard that will be activated to cover the needle after the injection is finished. The safety guard will help to prevent needlestick injuries to anyone who handles the pre-filled syringe after injection.
- **Do not** try to re-use or take apart the pre-filled syringe.
- **Do not** pull back on the plunger.

### Store Xolair

- Store in a refrigerator (2°C to 8°C). The carton containing the pre-filled syringe can be stored for a total time of 48 hours at room temperature (25°C) before use. It can be placed back in the refrigerator if necessary.
- **Do not** freeze.
- Keep the pre-filled syringe in the original carton until ready to use in order to protect from light.
- Keep the pre-filled syringe out of sight and reach of children.

### Dosing table











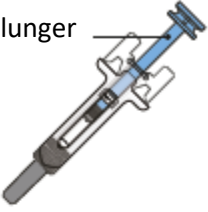

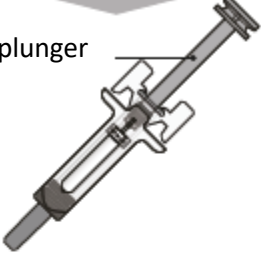









Xolair pre-filled syringes are available in 3 dose strengths (one pre-filled syringe in each carton). These instructions are to be used for all 3 dose strengths.

Depending on the dose prescribed to you by your doctor, you may need to select one or more pre-filled syringes, and inject the contents of them all in order to deliver your full dose. The Dosing Table below shows the combination of pre-filled syringes needed to deliver your full dose.



**Important:** If the dose is for a child under age 12 it is recommended to use only blue (75 mg) and purple (150 mg) pre-filled syringes. Refer to the Dosing Table below for the recommended combination of pre-filled syringes for children under age 12.

Contact your doctor if you have questions on the Dosing Table.

		Xolair 75 mg pre-filled syringe with a blue plunger			Xolair 150 mg pre-filled syringe with a purple plunger			Xolair 300 mg pre-filled syringe with a gray plunger		
		Blue plunger 			Purple plunger 			Gray plunger 		
DOSE	Prefilled syringes needed for dose	Blue 75 mg	Purple 150 mg	Gray 300 mg						
75 mg	1 blue									
150 mg	1 purple									
225 mg	1 blue + 1 purple									
300 mg (ages 12 and up)	1 gray									
300 mg (children under age 12)	2 purple									
375 mg (ages 12 and up)	1 blue + 1 gray									
375 mg (children under age 12)	1 blue + 2 purple									
450 mg (ages 12 and up)	1 purple + 1 gray									
450 mg (children under age 12)	3 purple									
525 mg (ages 12 and up)	1 blue + 1 purple + 1 gray									
525 mg (children under age 12)	1 blue + 3 purple									
600 mg (ages 12 and up)	2 gray									
600 mg (children under age 12)	4 purple									

## Prepare to inject Xolair

### Step 1. Bring to room temperature

Take the carton containing the pre-filled syringe out of the refrigerator **and leave it unopened so that it reaches room temperature (minimum 30 minutes)**.

Note: If you need more than one pre-filled syringe (one pre-filled syringe per carton) to deliver your full dose (see Dosing Table), take all the cartons out of the refrigerator at the same time.

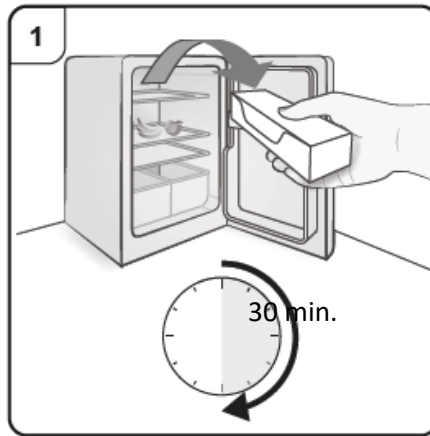

### Step 2. Gather supplies

You will need the following supplies (not included in the carton):

- Alcohol wipe
- Cotton ball or gauze pad
- Sharps disposal container
- Adhesive plaster

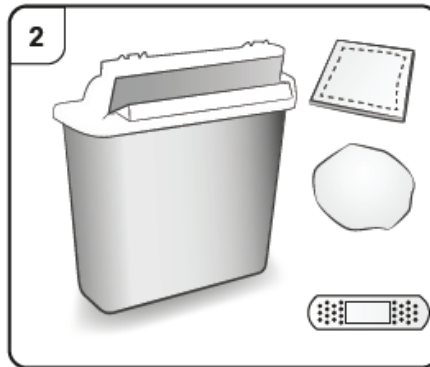

### Step 3. Unpack

Open the plastic tray by peeling away the cover. Remove the pre-filled syringe by holding it in the middle as shown.

**Do not** remove the needle cap until you are ready to inject.

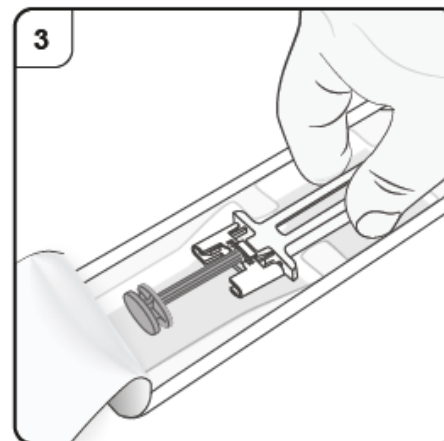

#### Step 4. Inspect the pre-filled syringe

Look through the viewing window of the pre-filled syringe.

The liquid inside should be clear to slightly cloudy. Its color may vary from colorless to pale brownish-yellow. You may see air bubbles in the liquid, which is normal. Do not try to remove the air.

- **Do not** use the pre-filled syringe if the liquid contains particles, or if the liquid looks distinctly cloudy or distinctly brown.
- **Do not** use the pre-filled syringe if it looks damaged or if it has leaked.
- **Do not** use the pre-filled syringe after the expiry date (EXP), which is printed on the pre-filled syringe label and carton.

In all of these cases, contact your doctor, nurse or pharmacist.

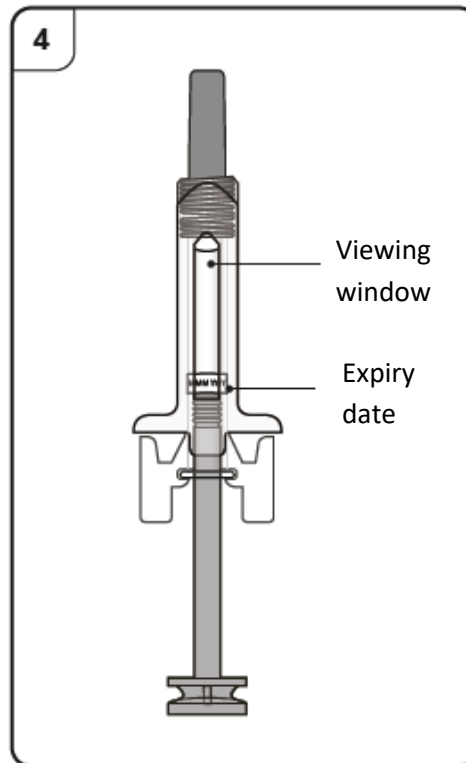

#### Step 5. Choose injection site

You should inject into the front of the thighs or the lower stomach area but not the area 5 cm around the belly button.

**Do not** inject into skin that is tender, bruised, red, scaly or hard or into areas with scars or stretch marks.

Note: If you need more than one pre-filled syringe to deliver your full dose, make sure your injections are at least 2 cm apart.

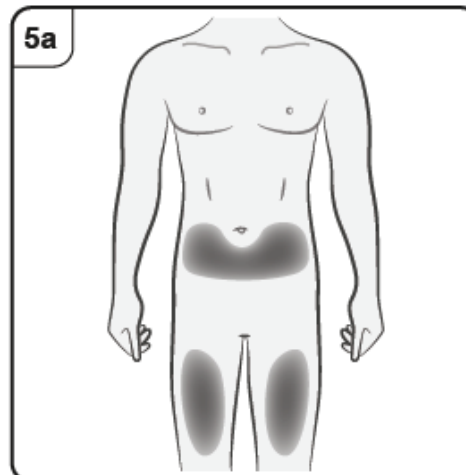

If your caregiver, doctor or nurse is giving you the injection, they may also inject into the outer upper arm.

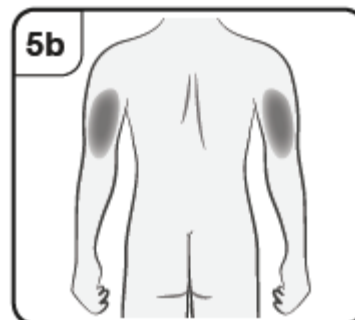

## Inject with Xolair

### Step 6. Clean injection site

Clean your hands.

Clean the chosen injection site with an alcohol wipe. Leave it to dry before injecting.

**Do not** touch or blow on the cleaned skin before injecting.

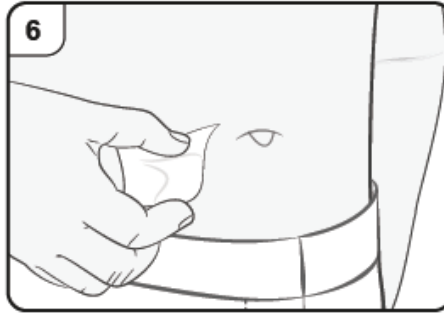

### Step 7. Remove needle cap

Firmly pull straight to remove the needle cap from the pre-filled syringe. You may see a drop of liquid at the end of the needle. This is normal.

**Do not** put the needle cap back on.

Throw away the needle cap.

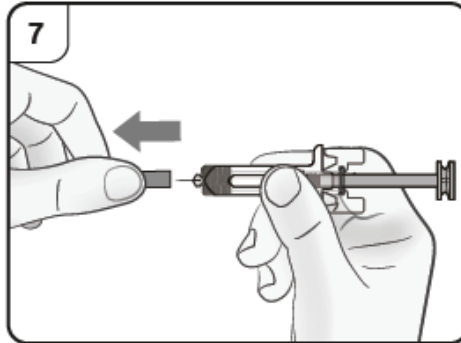

### Step 8. Insert needle

Gently pinch the skin at the injection site and hold the pinch throughout the injection. With the other hand insert the needle into the skin at an angle of approximately 45 degrees as shown.

**Do not** press the plunger while inserting the needle.

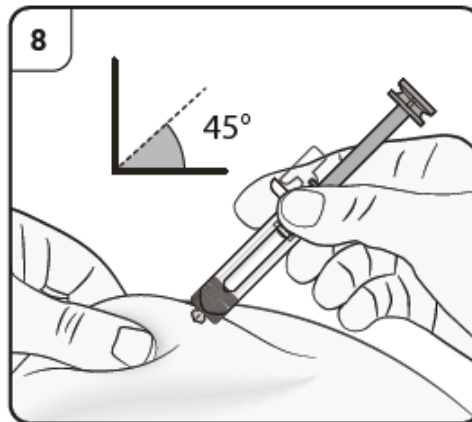

### Step 9. Start injection

Continue to pinch the skin. Slowly press the plunger **as far as it will go**. This will ensure that a full dose is injected.

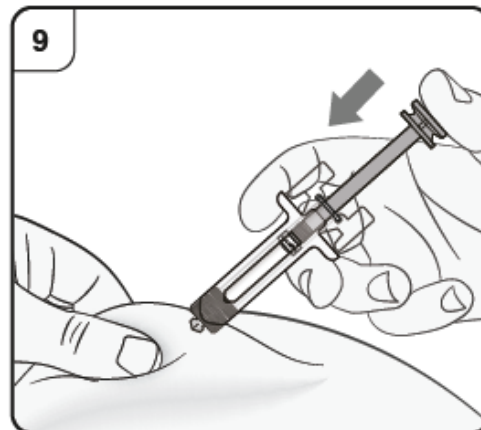

### Step 10. Complete injection

Confirm that the plunger head is between the safety guard wings as shown. This will ensure that the safety guard has been activated and will cover the needle after the injection is finished.

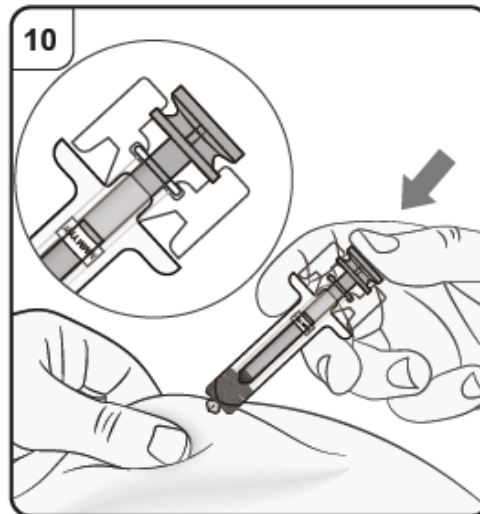

### Step 11. Release plunger

Keeping the pre-filled syringe at the injection site, slowly release the plunger until the needle is covered by the safety guard. Remove the pre-filled syringe from the injection site and release the pinch.

There may be a small amount of blood at the injection site. You can press a cotton ball or gauze pad over the injection site until any bleeding stops. **Do not** rub the injection site. If needed, cover the injection site with a small adhesive plaster.

Note: If you need more than one pre-filled syringe to deliver your full dose, throw away the used pre-filled syringe as described in Step 12.

Repeat Step 2 to Step 12 again for all the pre-filled syringes needed to deliver your full dose.

Carry out the injections immediately one after another.

Make sure the injections are at least 2 cm apart.

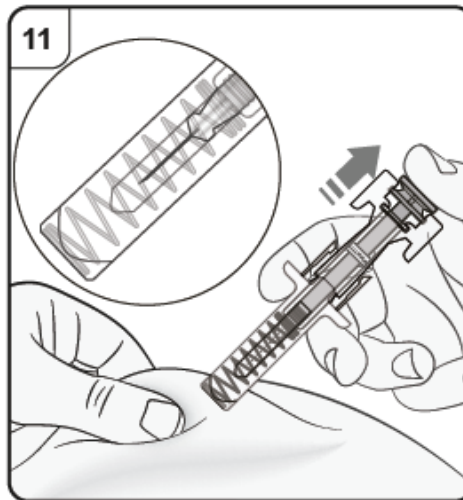

### After the injection

#### Step 12. Dispose of the pre-filled syringe

Put the used pre-filled syringe in a sharps disposal container (i.e. a puncture-resistant closable container, or similar) immediately after use.

**Do not** throw away the pre-filled syringe into household waste.

**Do not** try to put the needle cap back onto the syringe.

Talk to your doctor or pharmacist about proper disposal of the sharps disposal container. There may be local regulations for disposal.

